

PROJECT LEAD THE WAY

PLTW

Introduction to Dimensioning

1. Dimensions should reflect actual size of the object, not the scaled size.

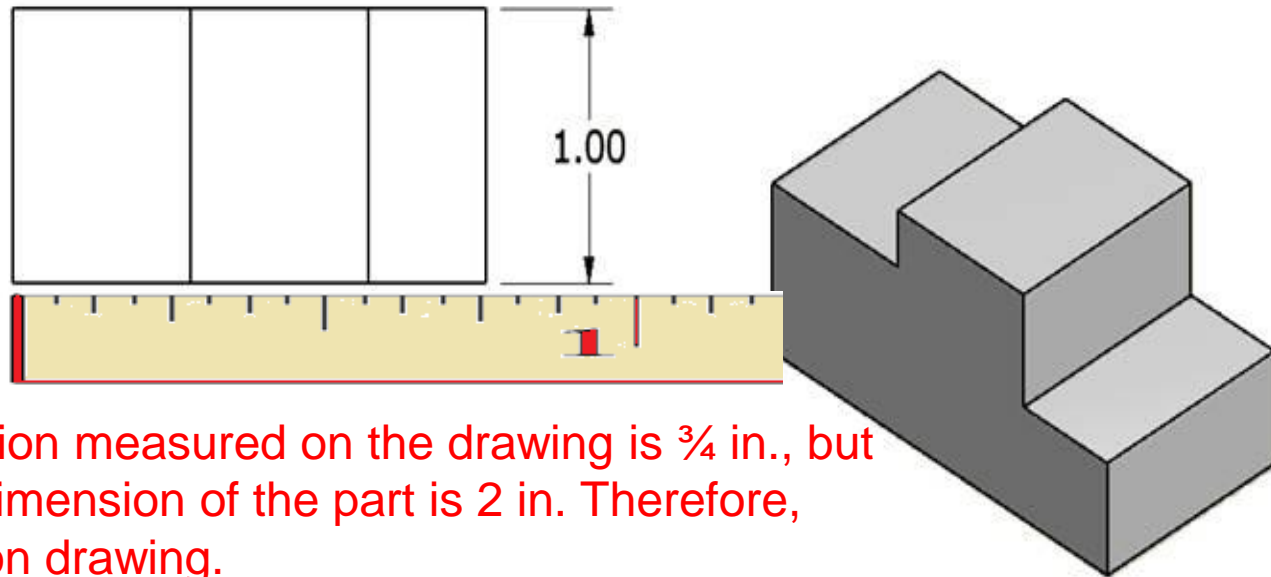

The dimension measured on the drawing is $\frac{3}{4}$ in., but the actual dimension of the part is 2 in. Therefore, show 2.00 on drawing.

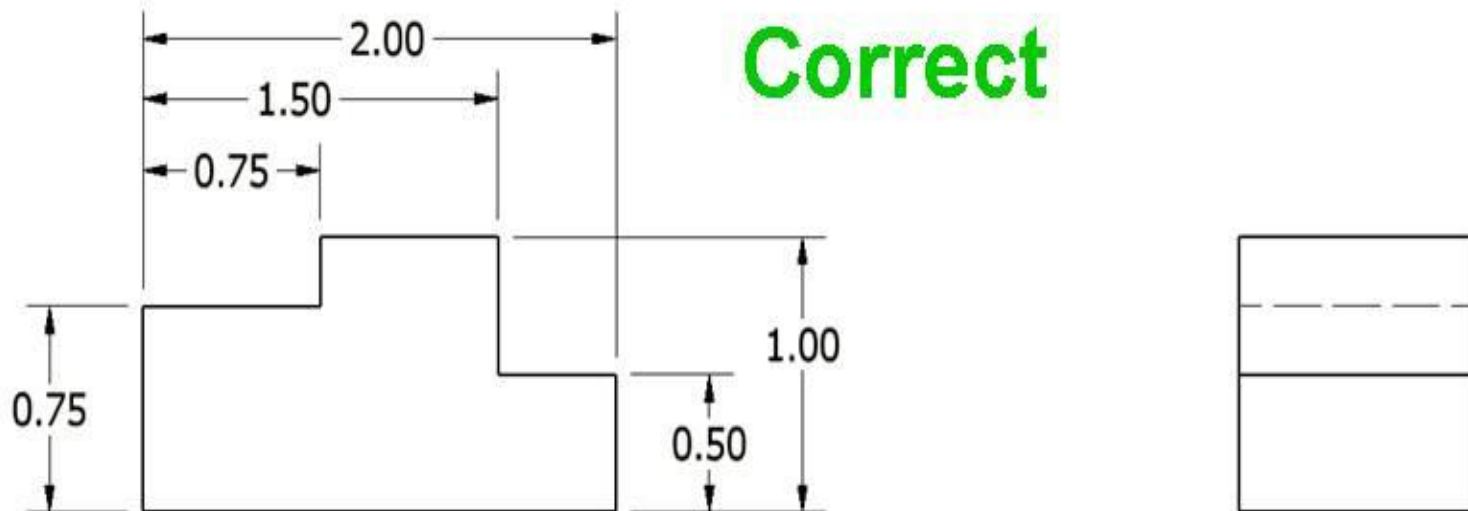

2. Include overall dimension in the three principle directions – width, height, and depth.

- Overall dimensions should be placed the greatest distance away from the object so that intermediate dimensions can nest closer to the object.

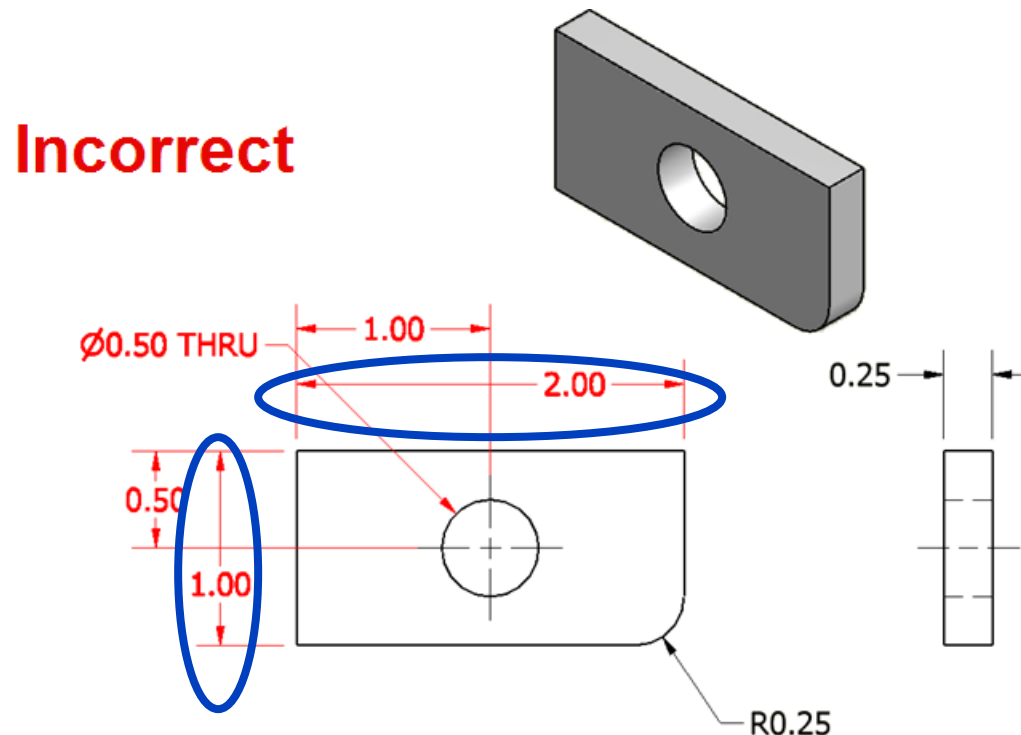

2. Include overall dimension in the three principle directions – width, height, and depth.

- Overall dimensions should be placed the greatest distance away from the object so that intermediate dimensions can nest closer to the object.

Correct

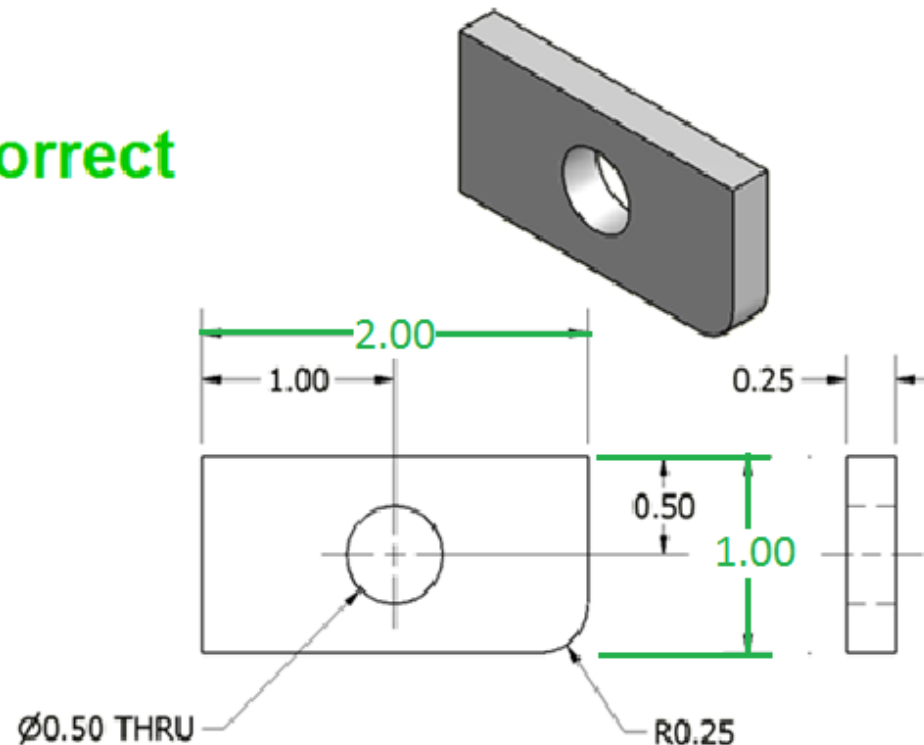

3. Include all dimensions necessary to produce or inspect the part.

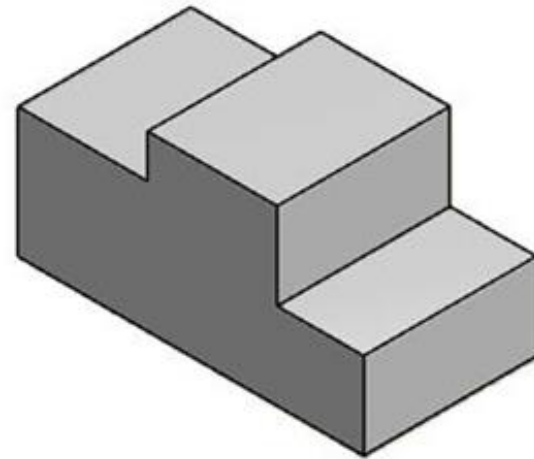
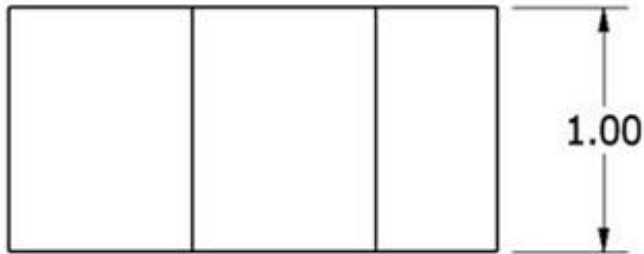

Dimensions should be placed so that it is not necessary to calculate or scale a dimension.

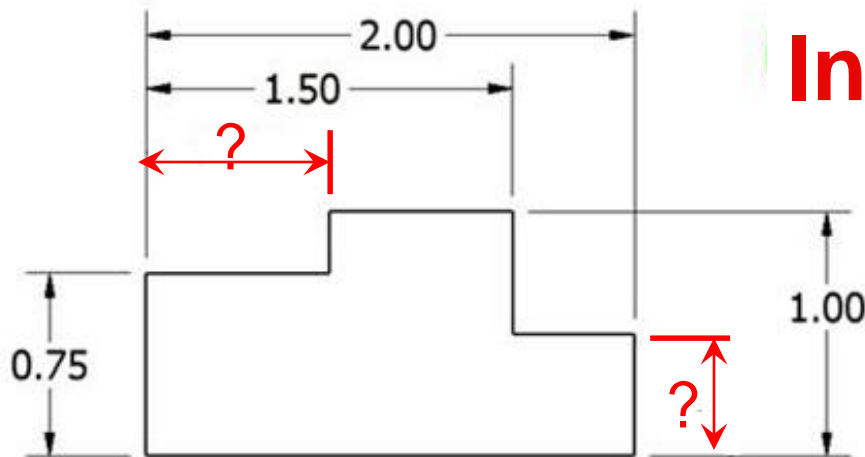

Incorrect

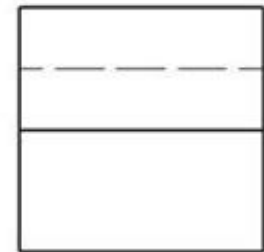

3. Include all dimensions necessary to produce or inspect the part.

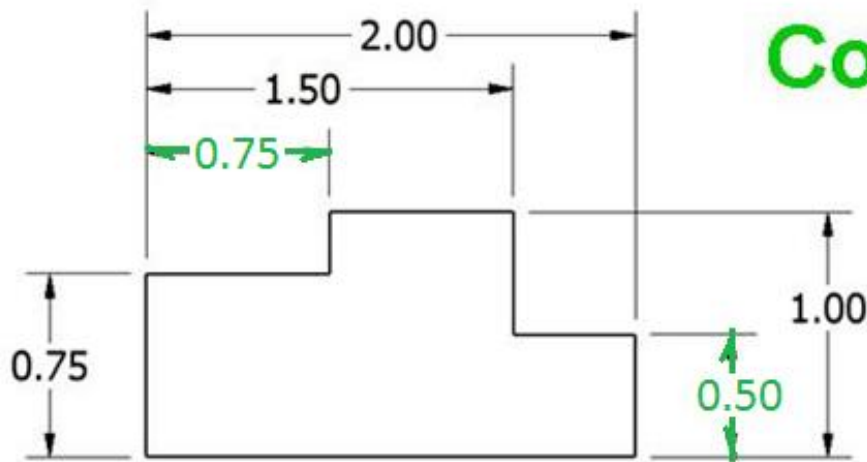
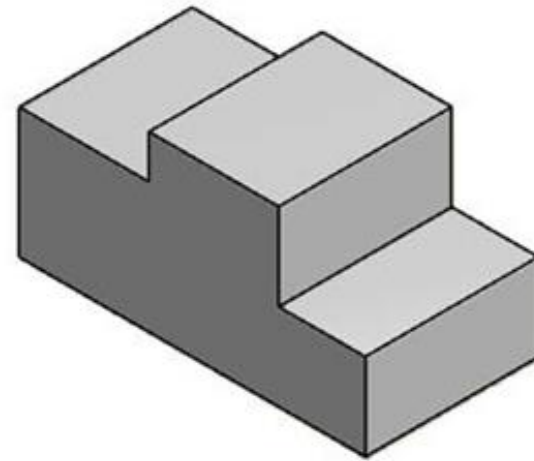

Correct

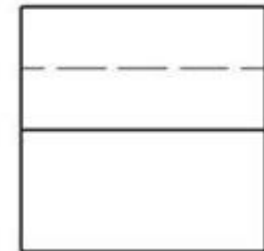

4. Do not include unnecessary dimensions.

Dimensions should NOT be duplicated or the same information given in two different ways.

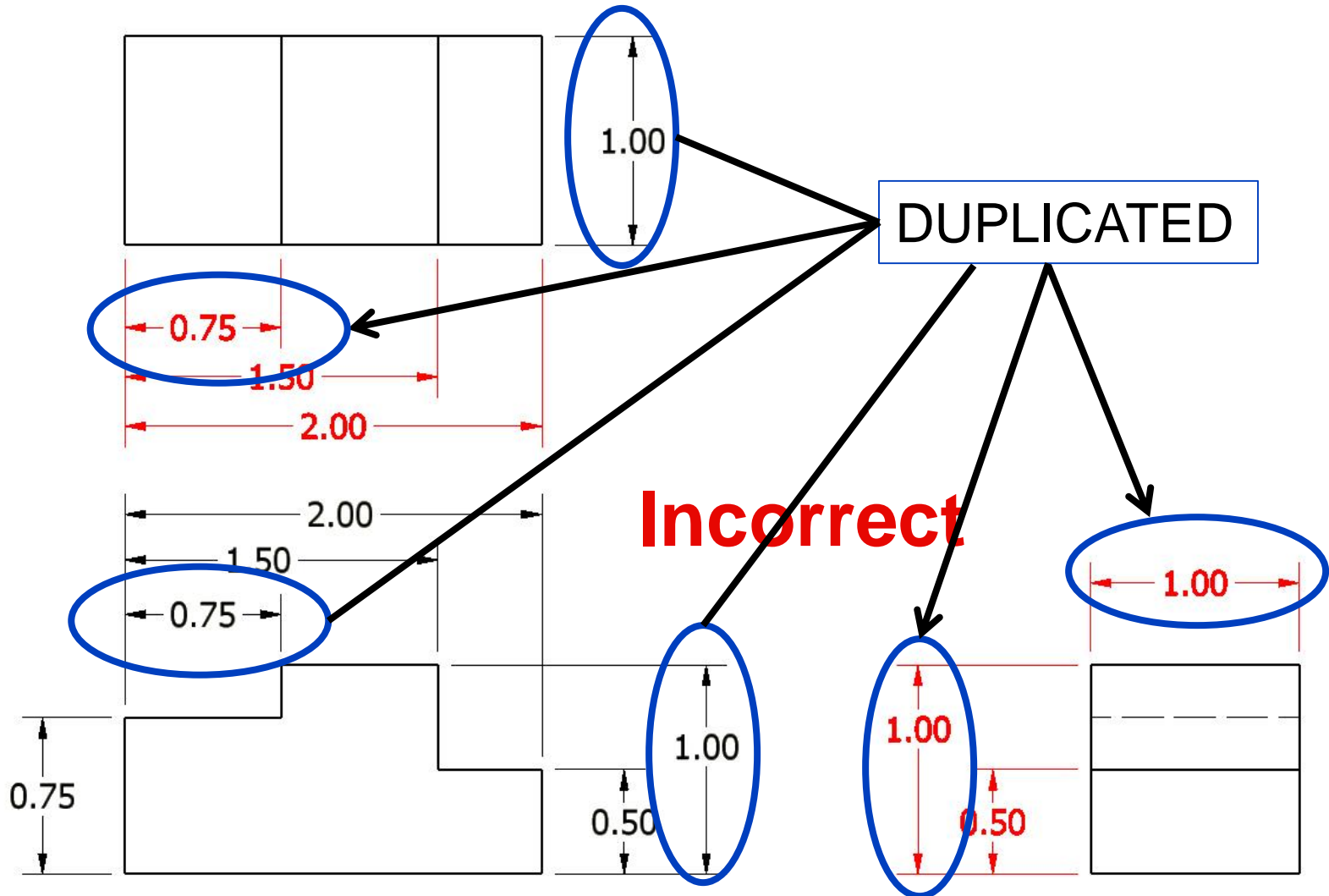

4. Do not include unnecessary dimensions.

Do not include chain dimensions that add up to a given overall dimension.

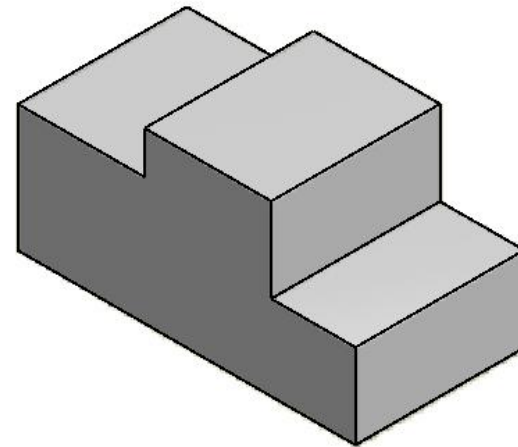
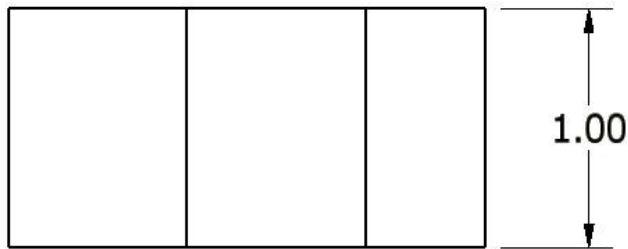

Provides the same information in two different ways.

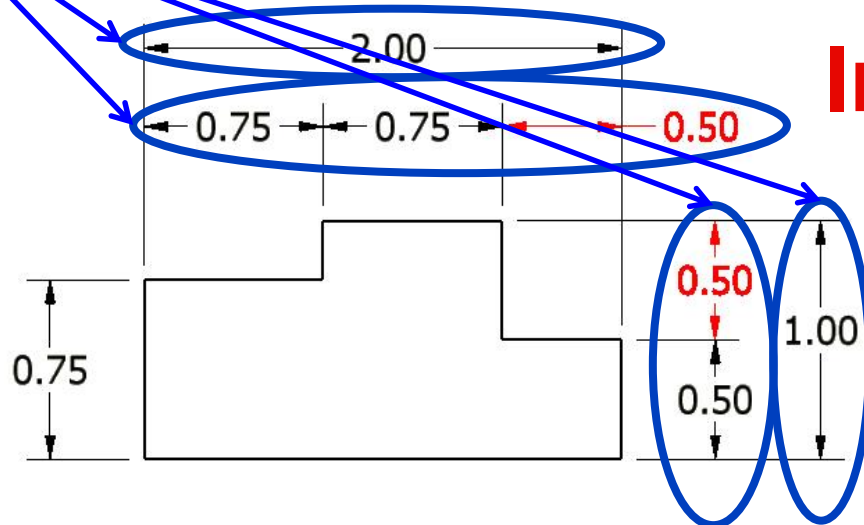

Incorrect

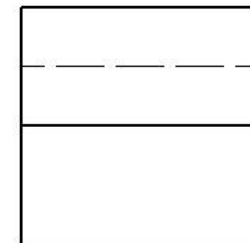

4. Do not include unnecessary dimensions.

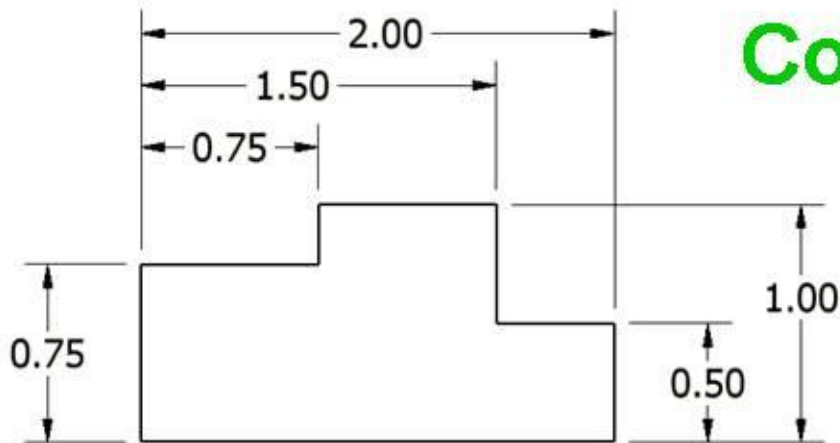
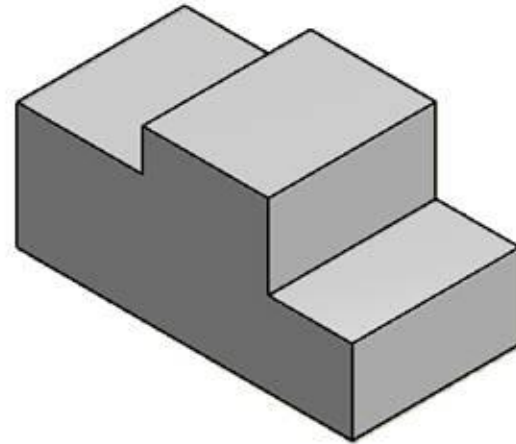

Correct

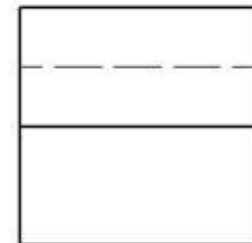

5. Dimensions should be attached to the view that best shows the ***contour*** of the feature to be dimensioned.

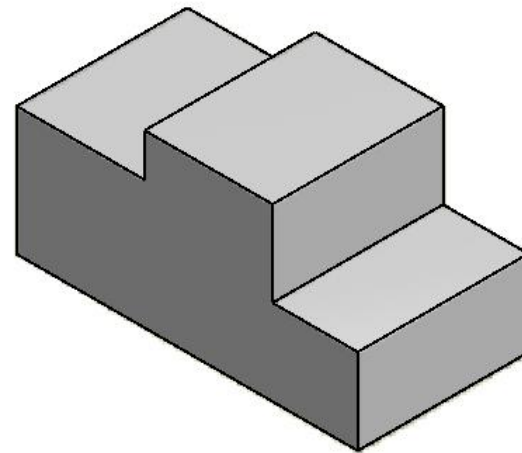

Incorrect

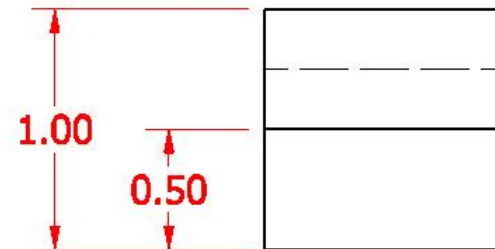
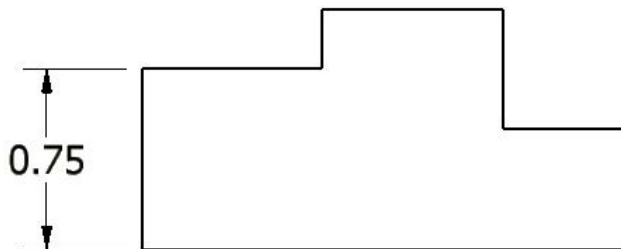

5. Dimensions should be attached to the view that best shows the ***contour*** of the feature to be dimensioned.

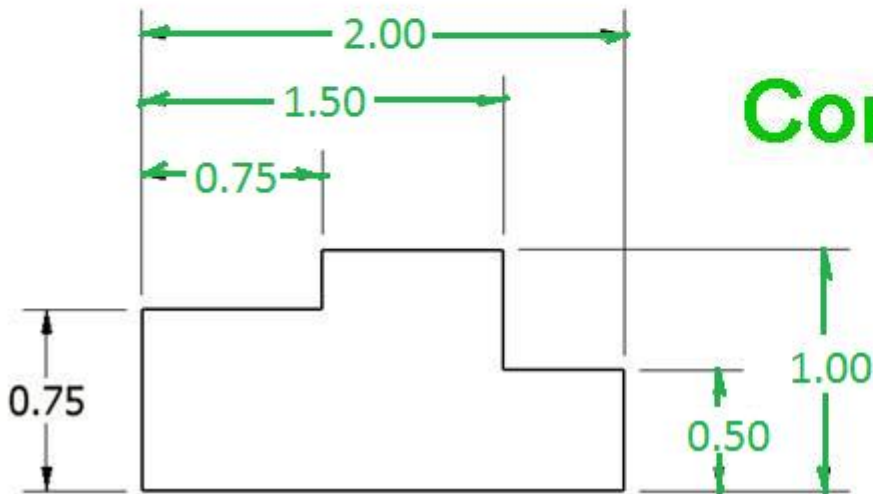
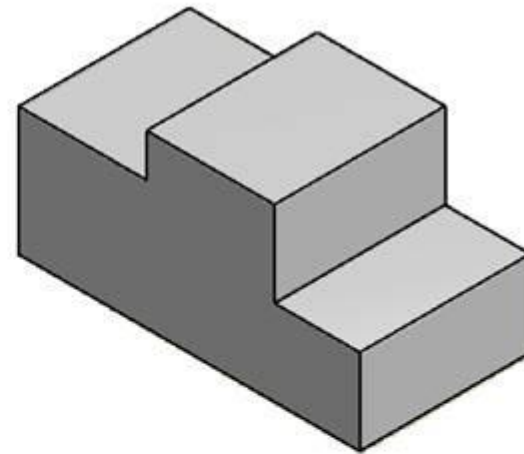
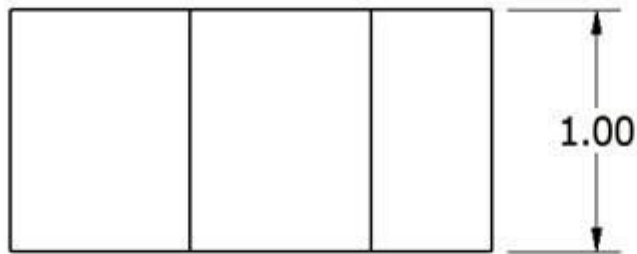

Correct

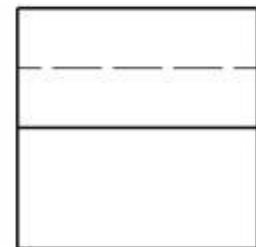

6. A dimension should be attached to only one view; for example, extension lines should not connect two views.

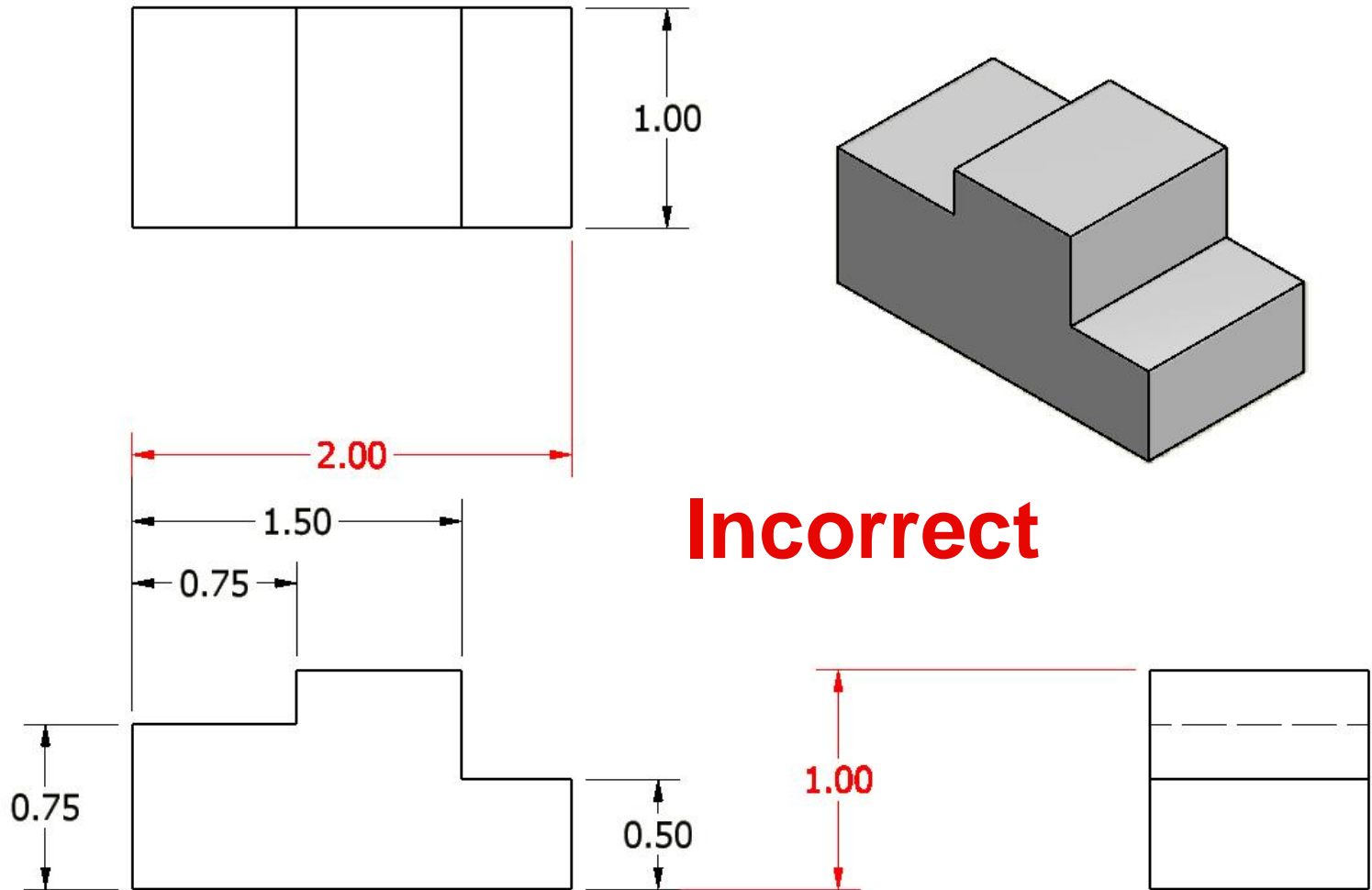

6. A dimension should be attached to only one view; for example, extension lines should not connect two views.

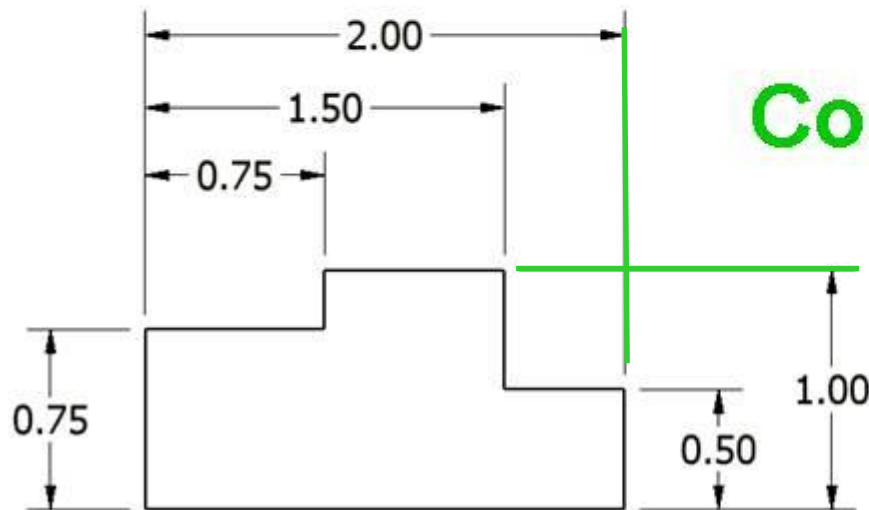
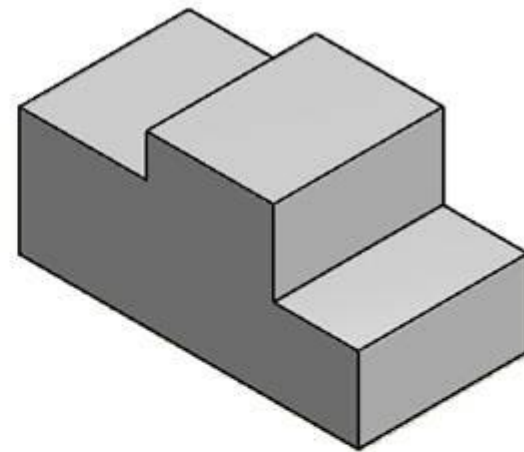
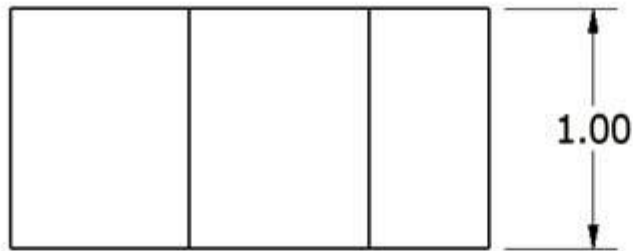

Correct

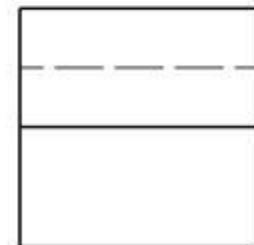

7. Whenever possible, locate dimensions between adjacent views.

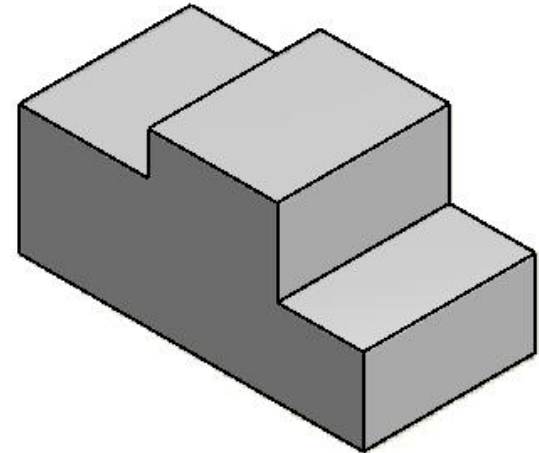
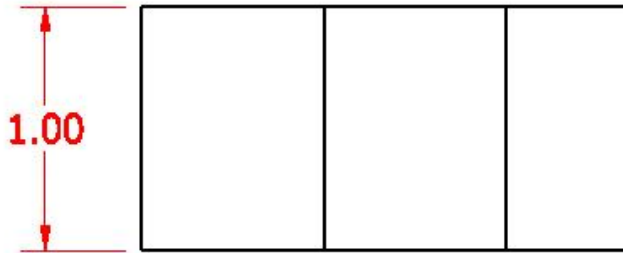

Incorrect

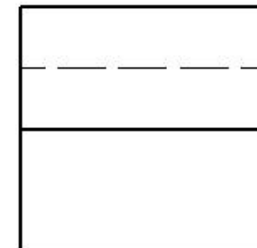
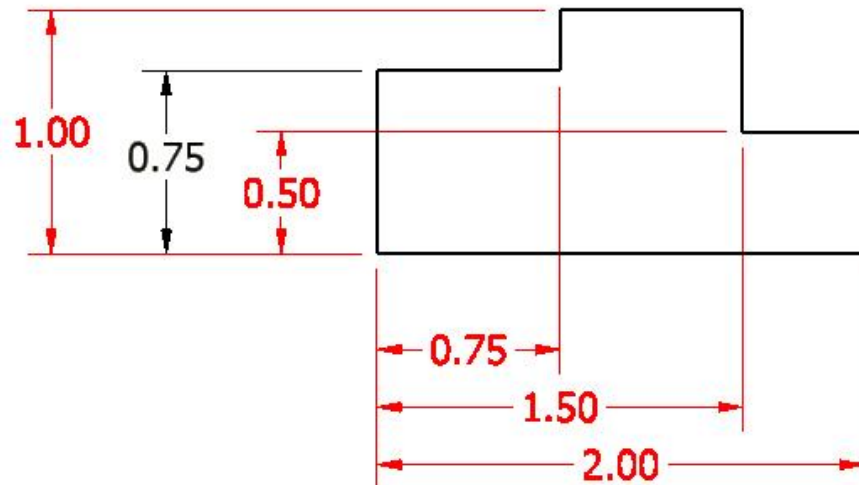

7. Whenever possible, locate dimensions between adjacent views.

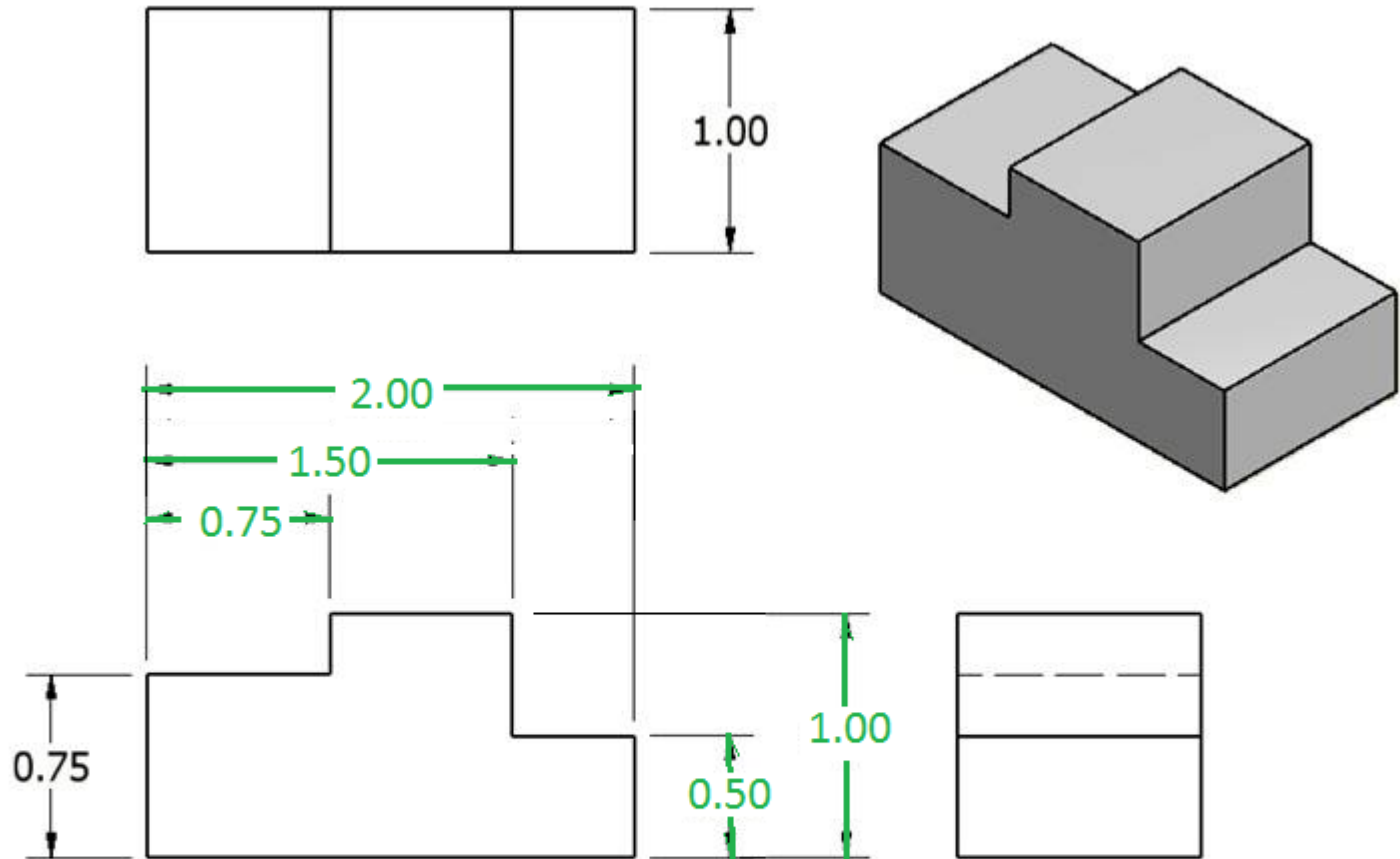

Correct

8. Avoid dimensioning to hidden lines.

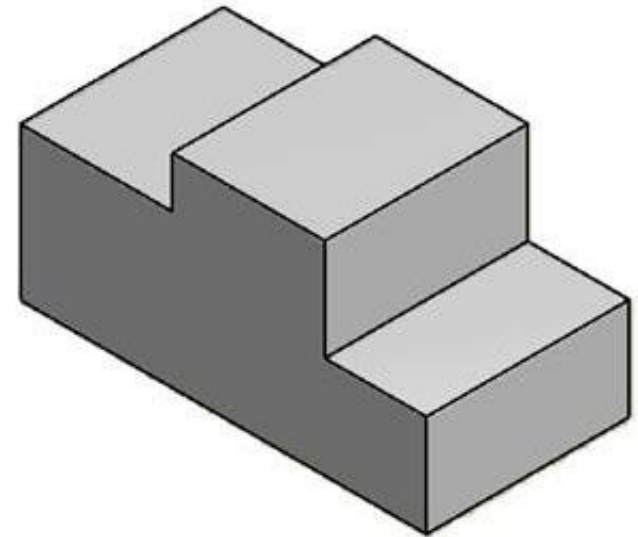
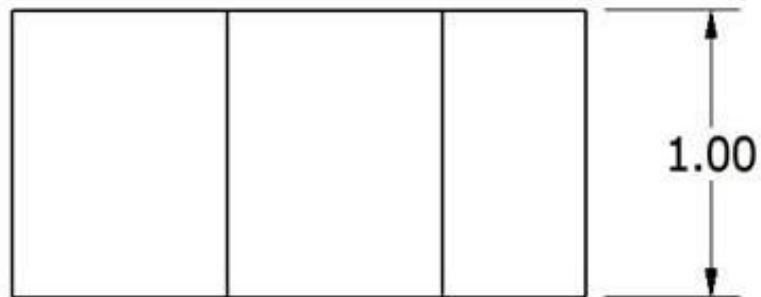

Incorrect

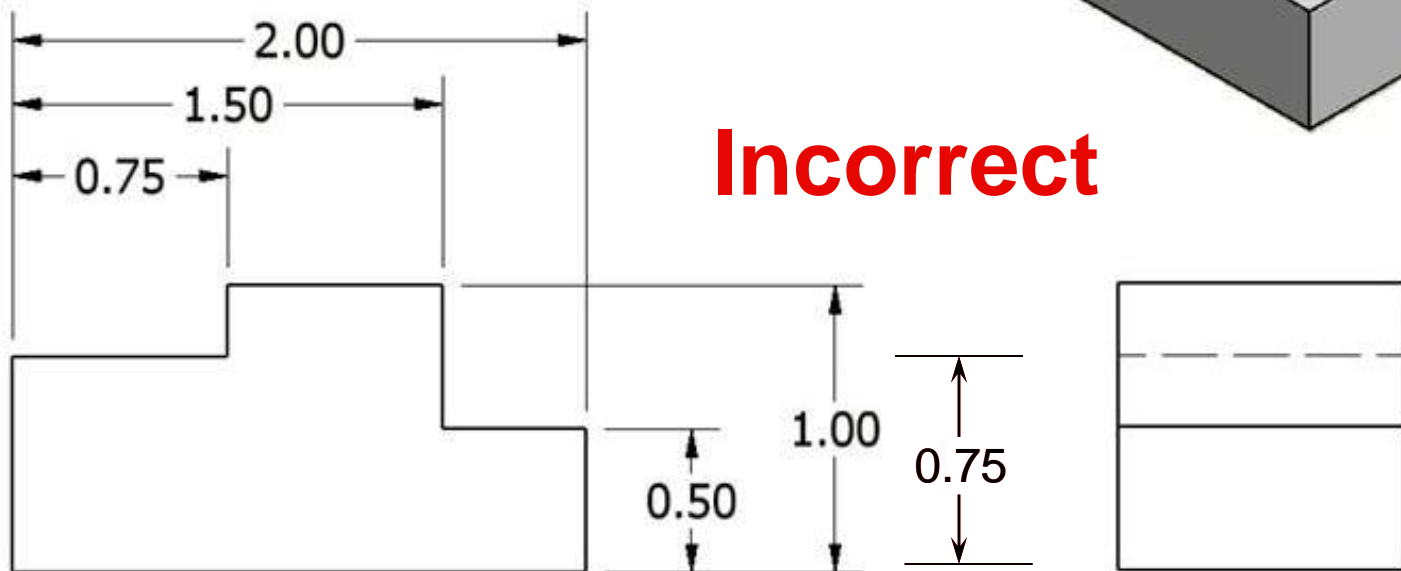

8. Avoid dimensioning to hidden lines.

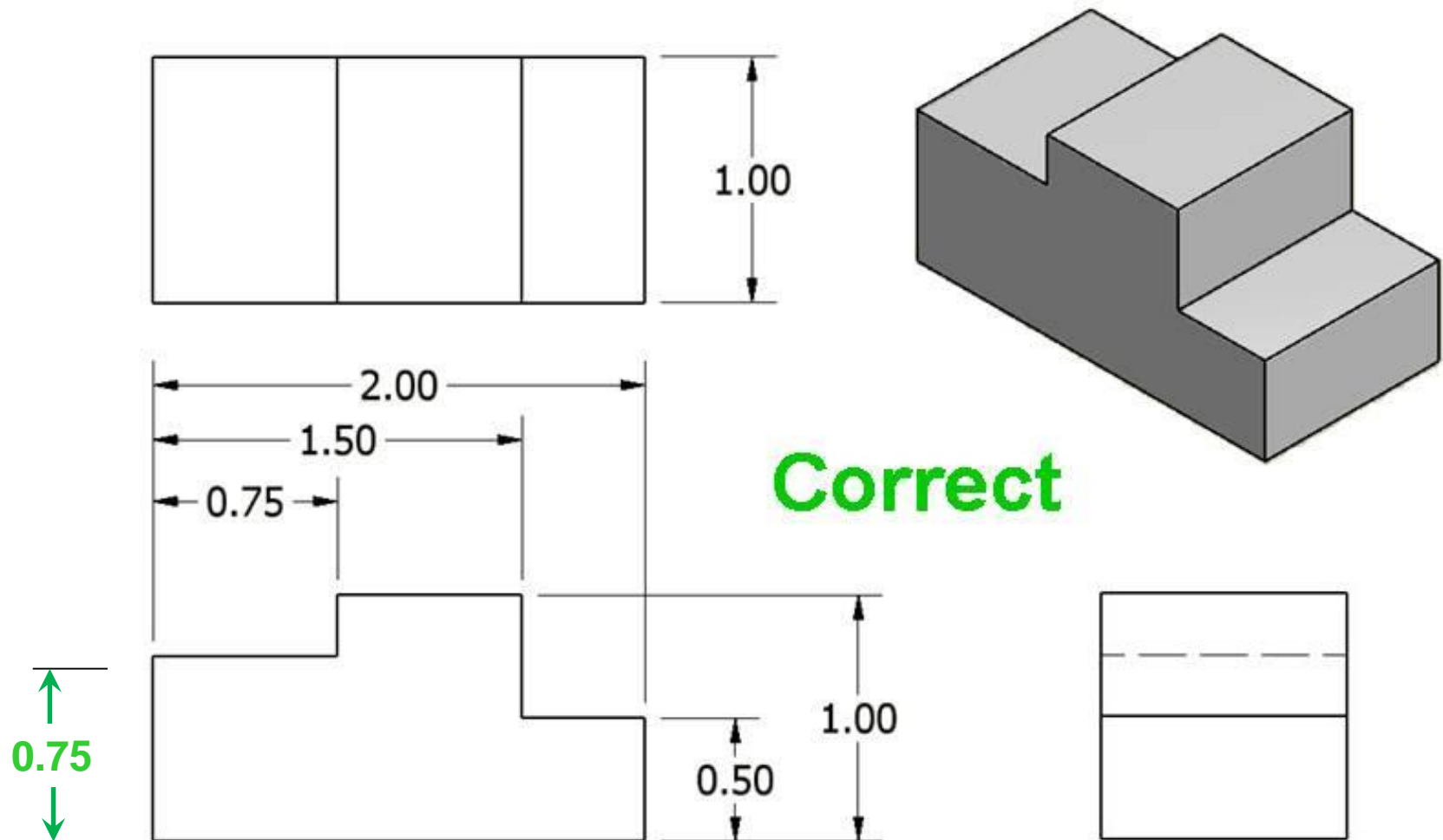

9. Do not place dimensions on the object unless it is absolutely necessary.

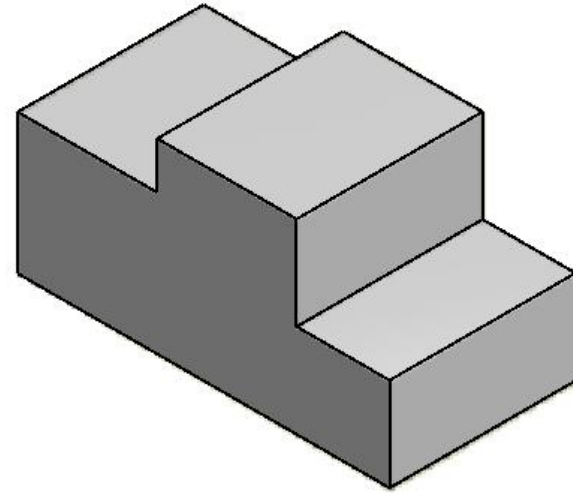

Incorrect

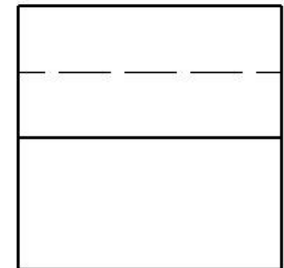
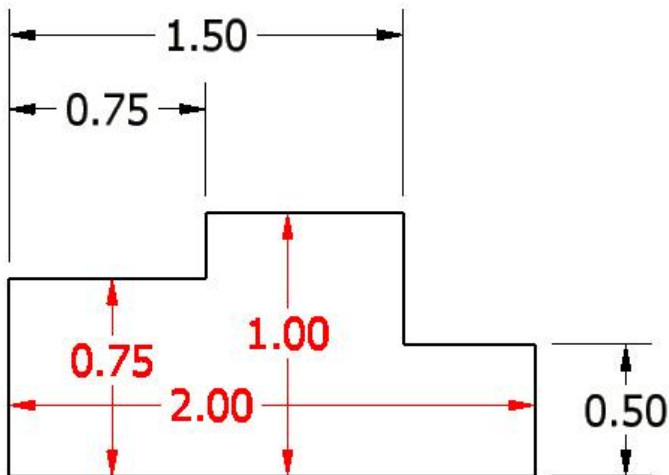

9. Do not place dimensions on the object unless it is absolutely necessary.

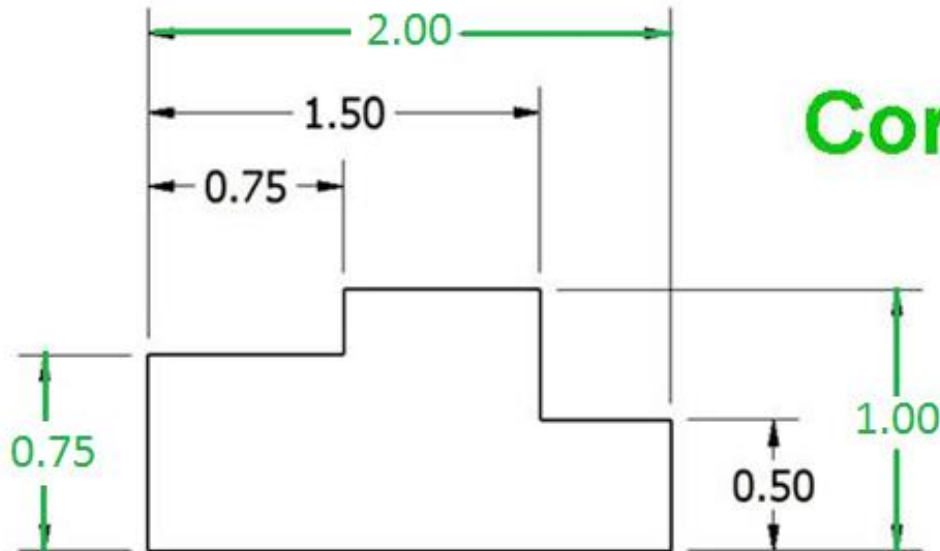
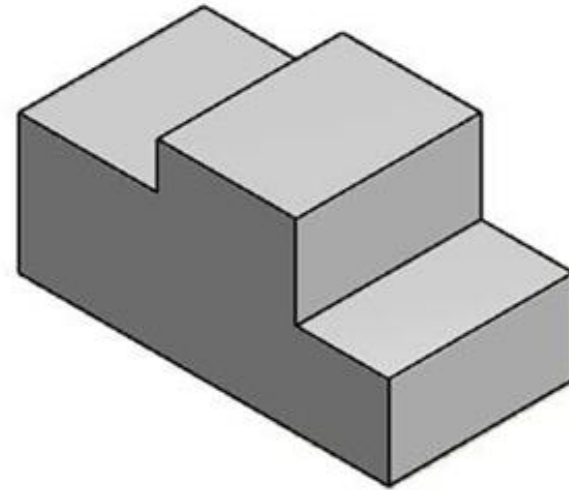
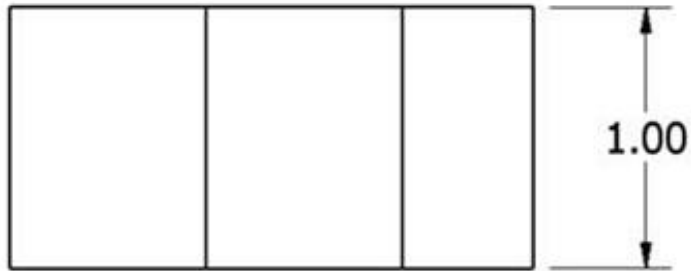

Correct

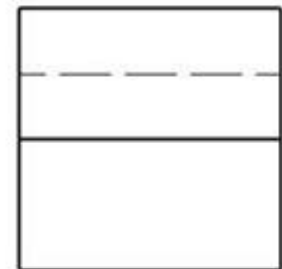

10. Do not cross a dimension line with another dimension line or with an extension line.

Incorrect

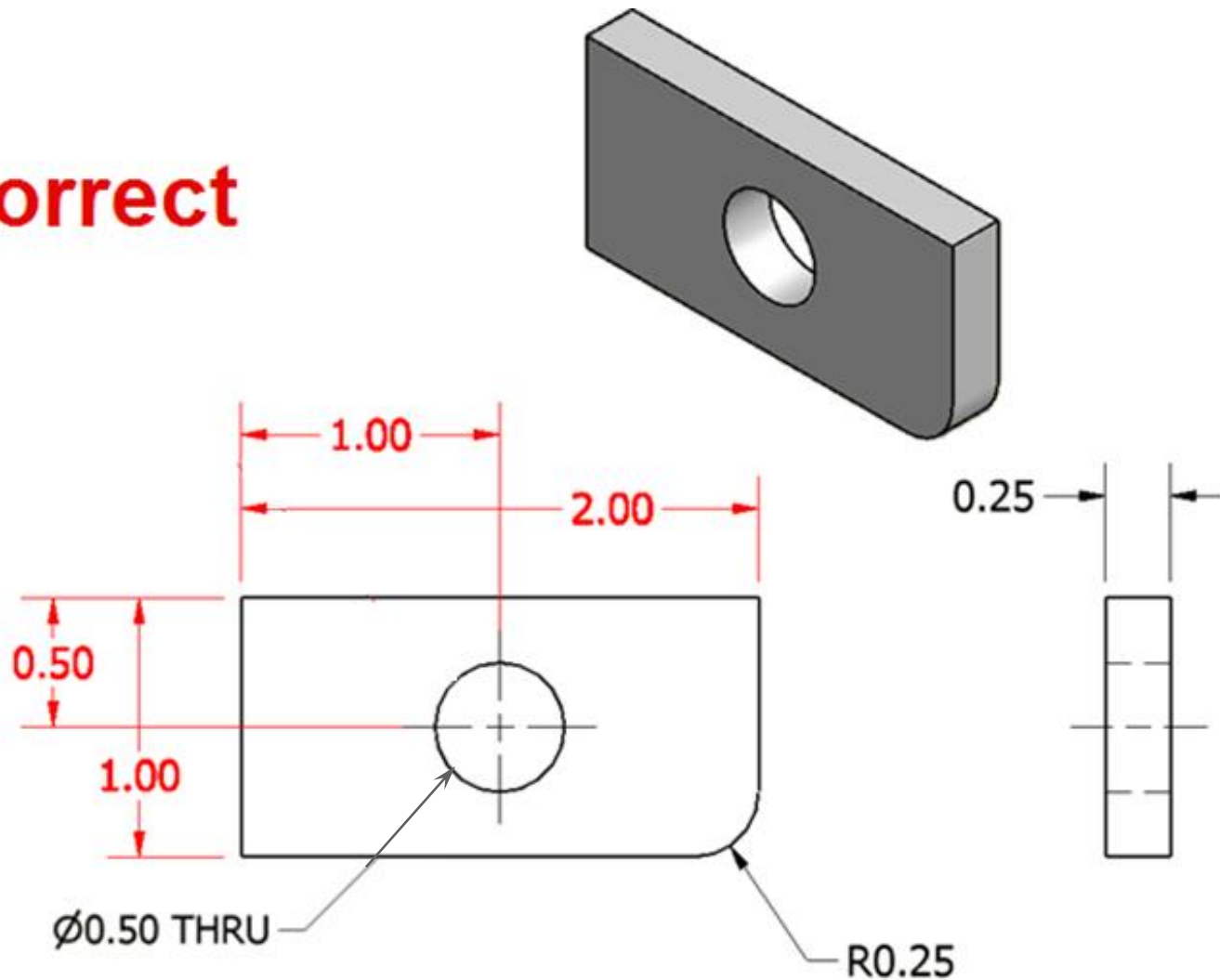

10. Do not cross a dimension line with another dimension line or with an extension line.

Correct

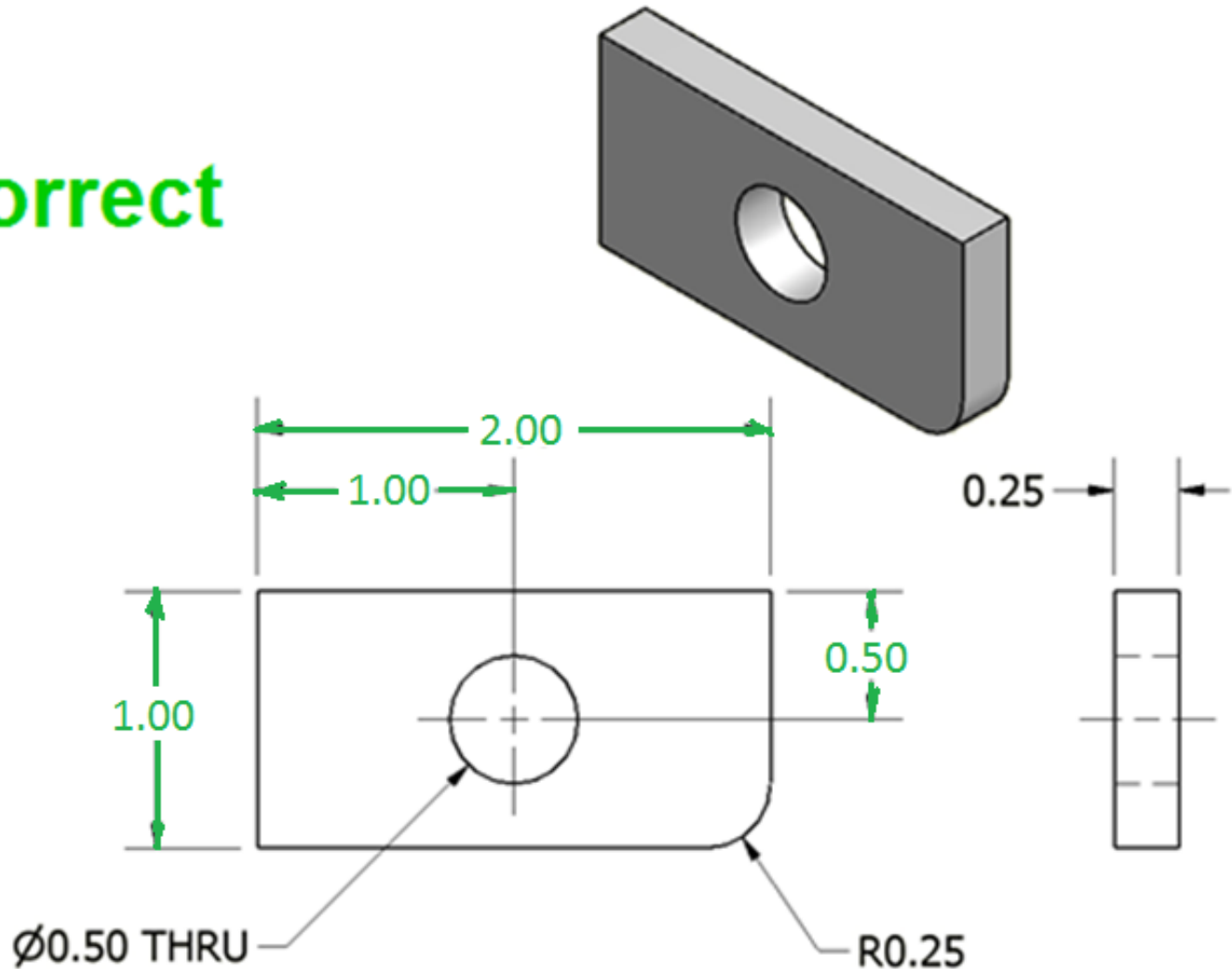

11. Avoid crossing dimension or extension lines with leader lines.

Incorrect

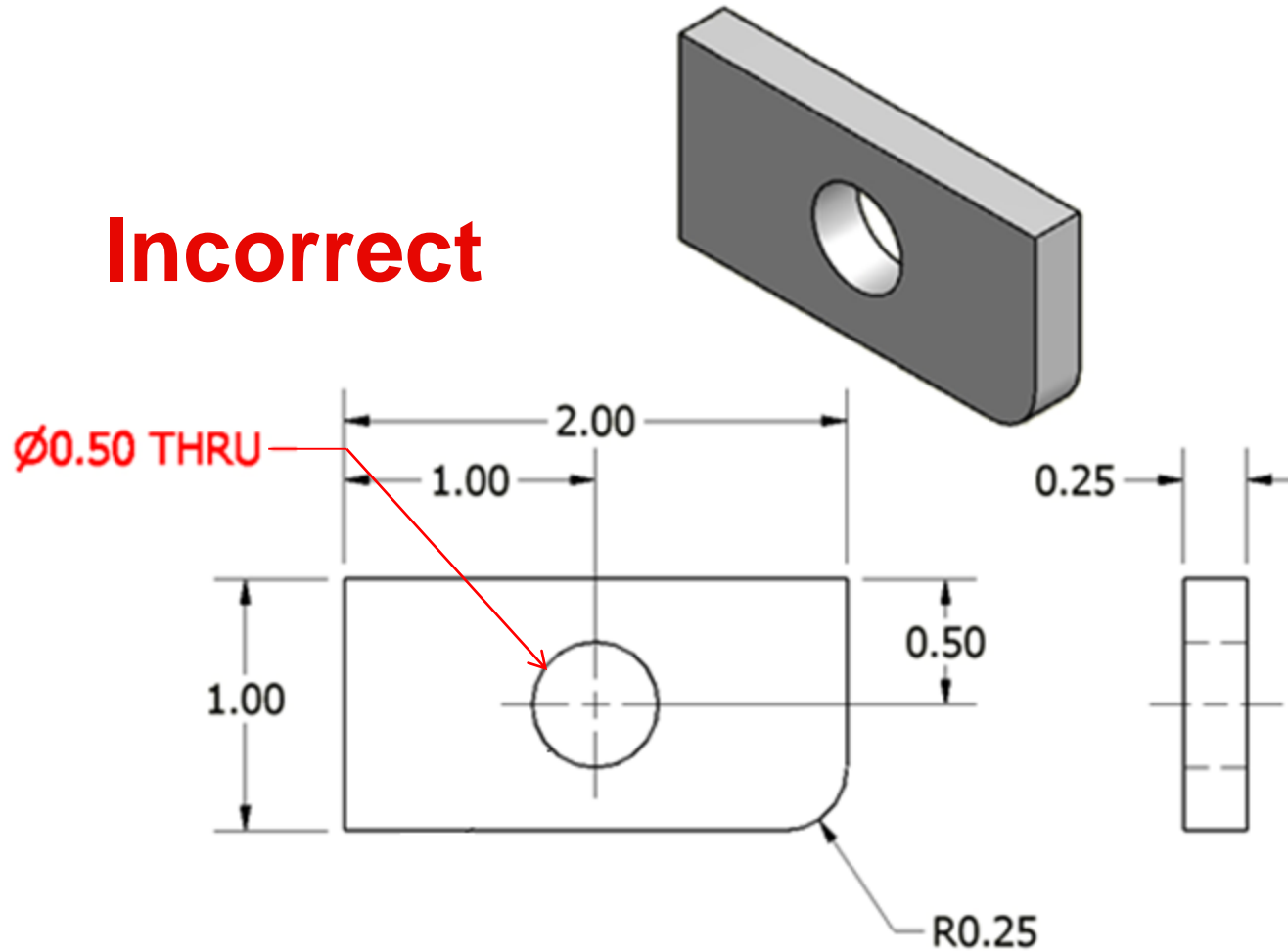

11. Avoid crossing dimension or extension lines with leader lines.

Correct

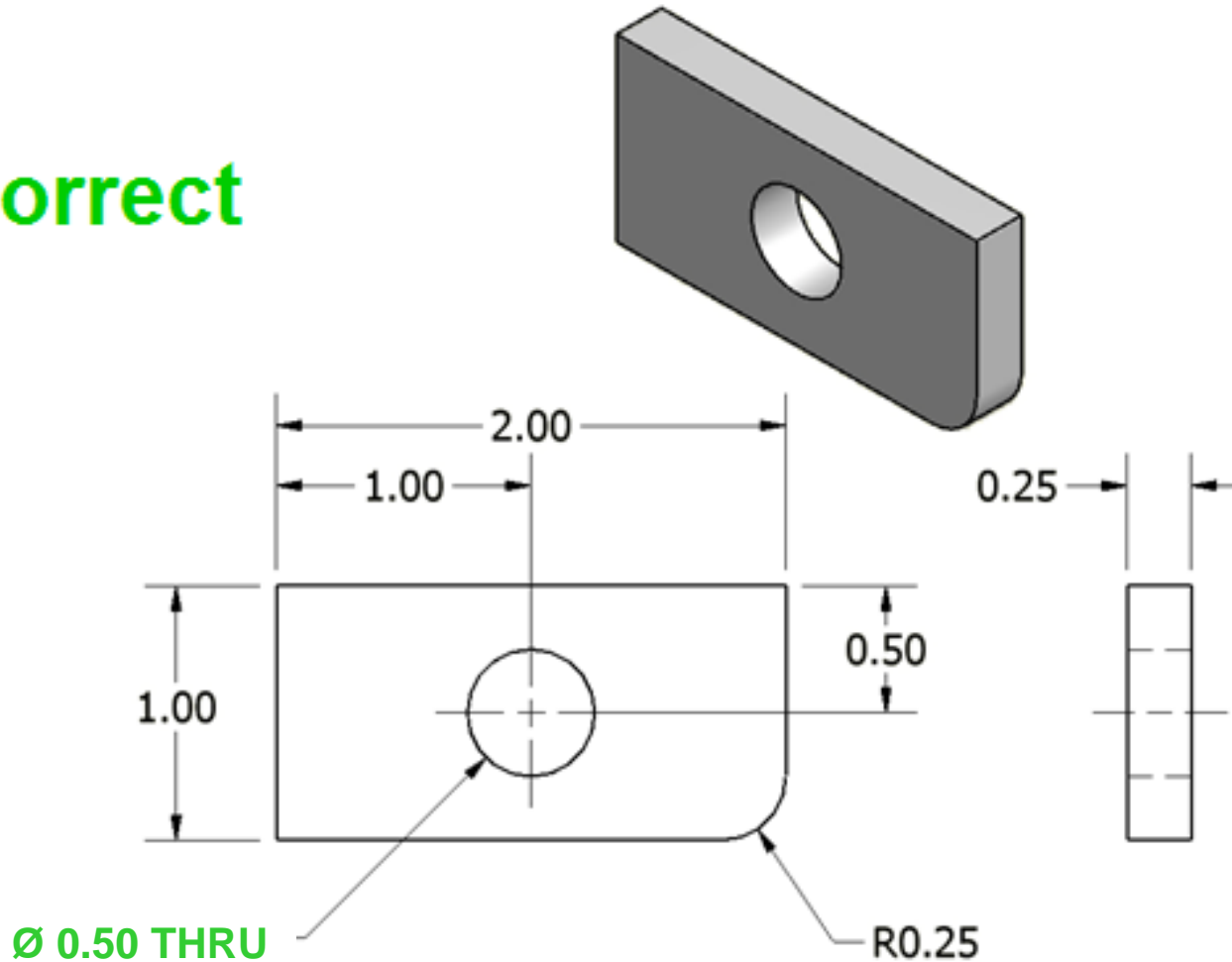

12. Leader lines point toward the center of the feature and should not occur horizontally or vertically.

This

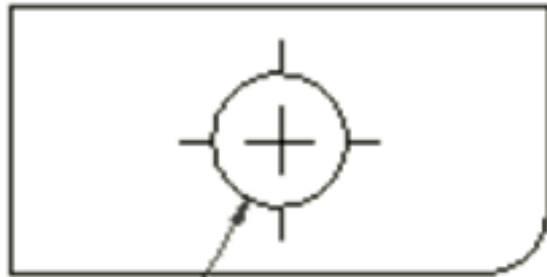

Ø0.50 THRU

Not This

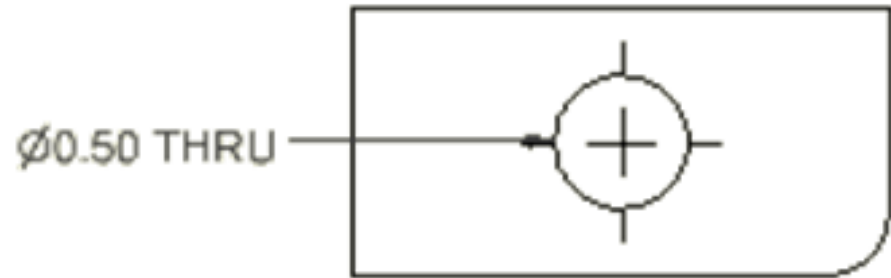

Ø0.50 THRU

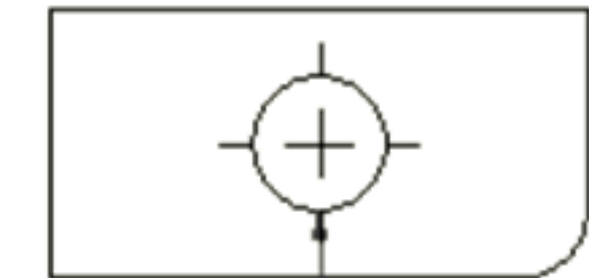

Ø0.50 THRU

13. Dimension numbers should be centered between arrowheads, except when using stacked dimensions, and then the numbers should be staggered.

Incorrect

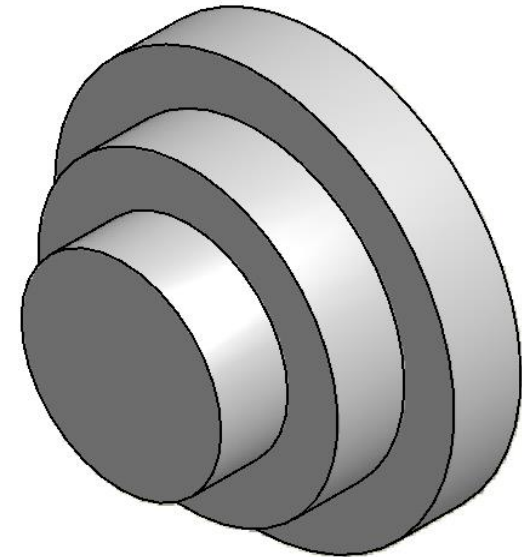
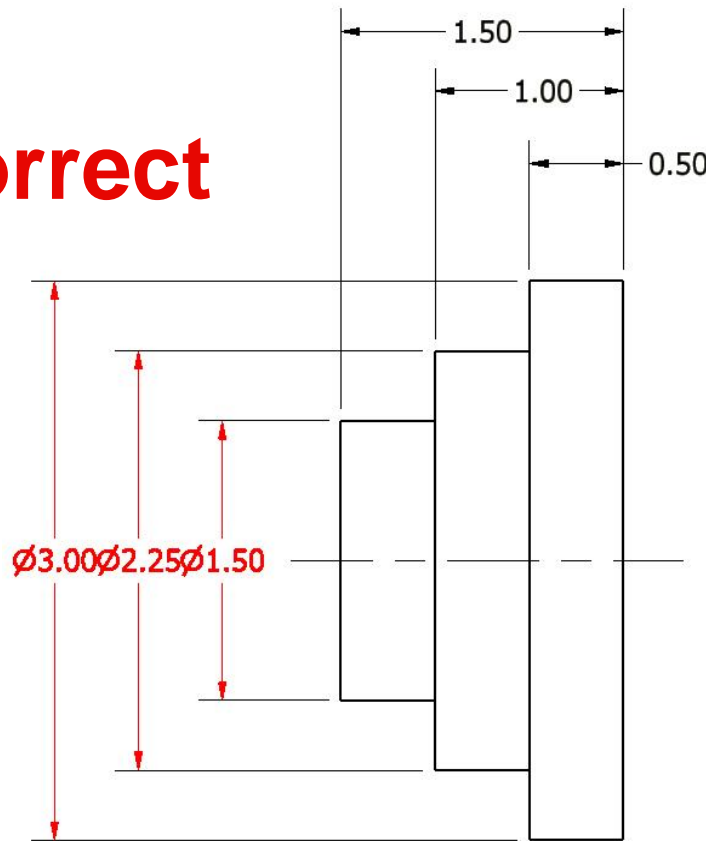

13. Dimension numbers should be centered between arrowheads, except when using stacked dimensions, and then the numbers should be staggered.

Correct

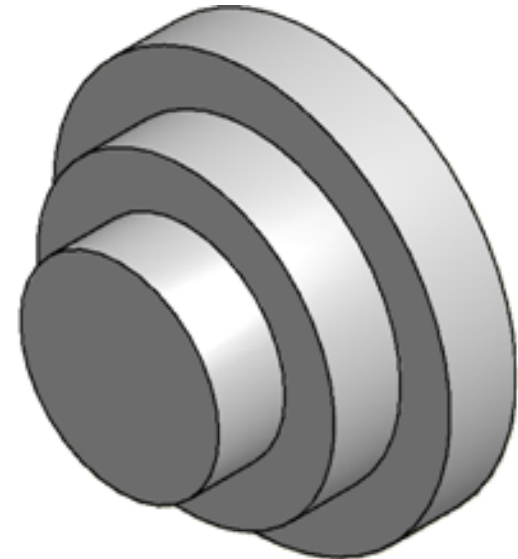
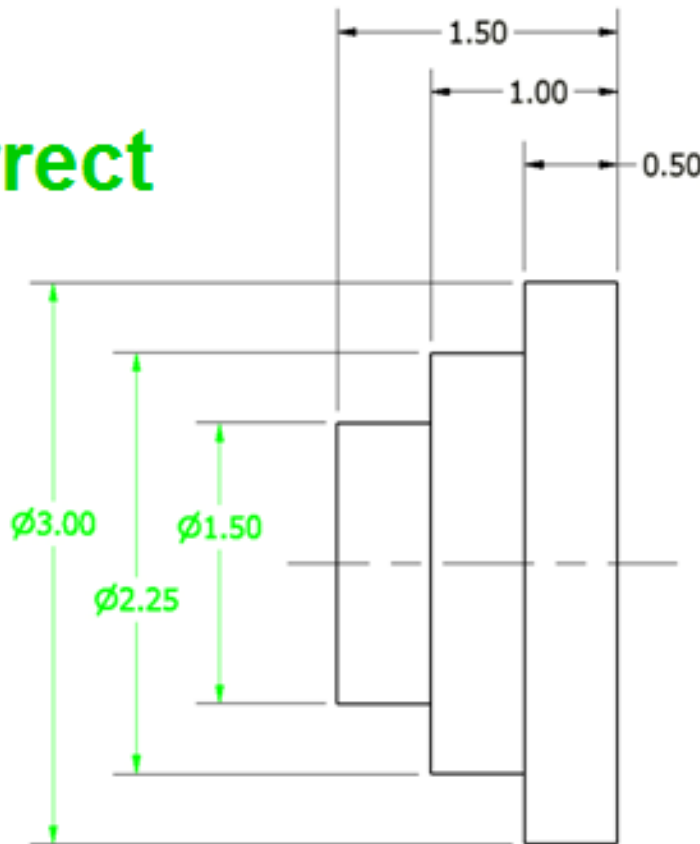

14. In general, a circle is dimensioned by its diameter and an arc by its radius.

Correct

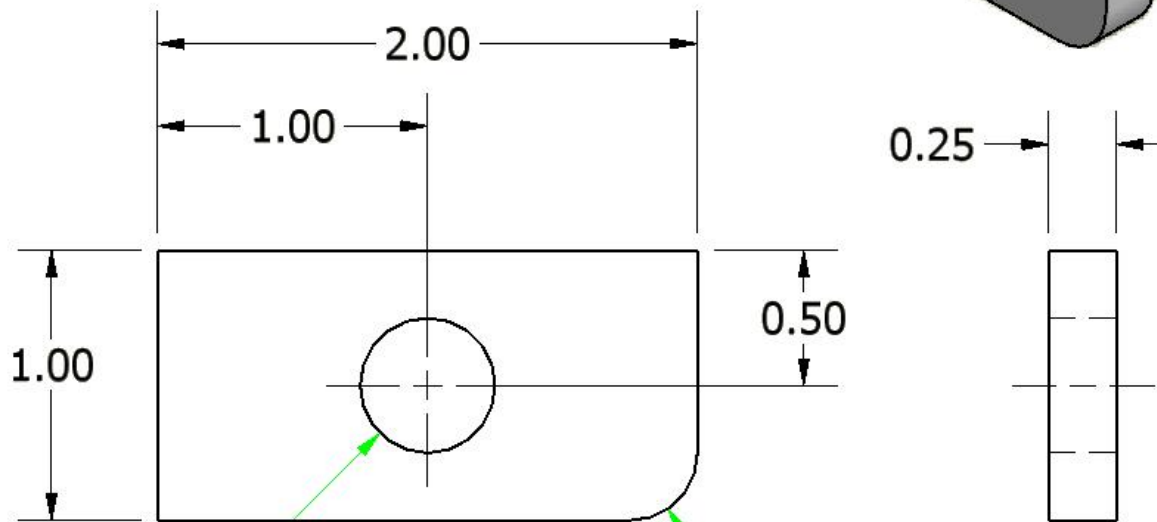
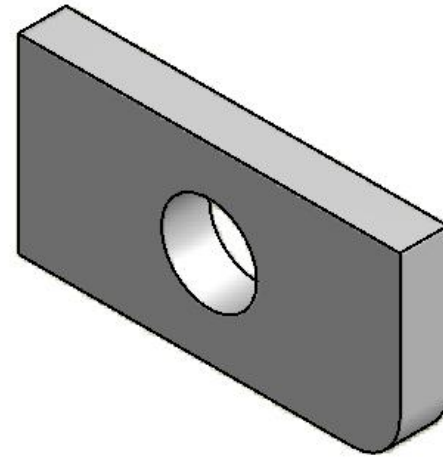

Ø0.50 THRU

R0.25

15. Holes should be located and sized in the view that shows the feature as a circle.

Incorrect

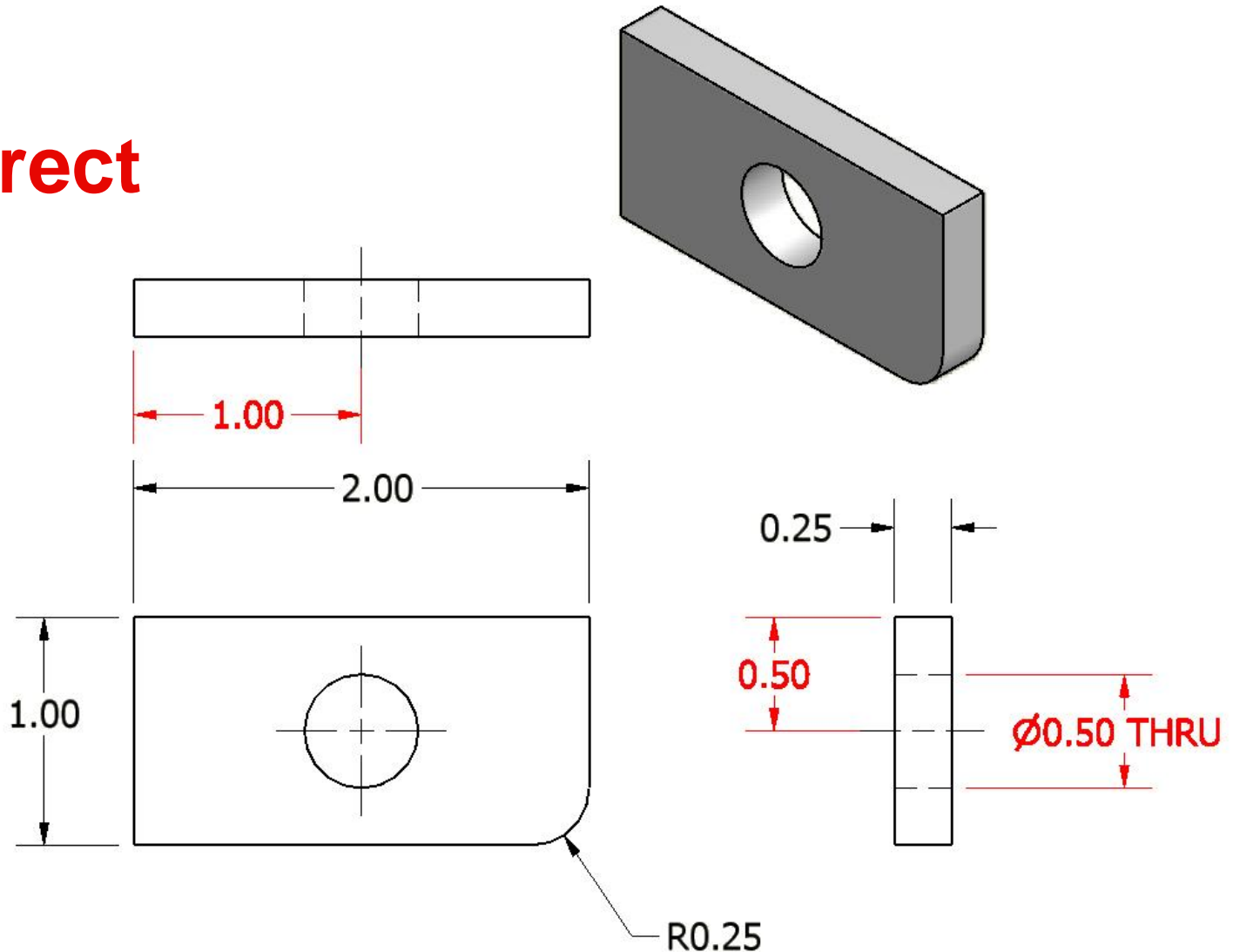

15. Holes should be located and sized in the view that shows the feature as a circle.

Correct

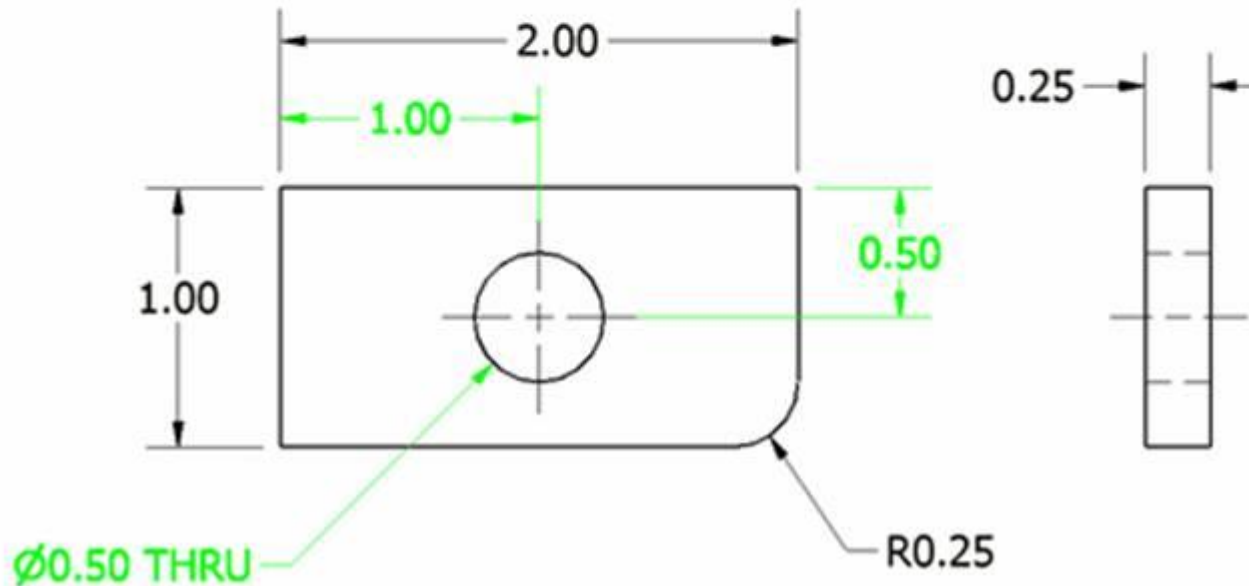
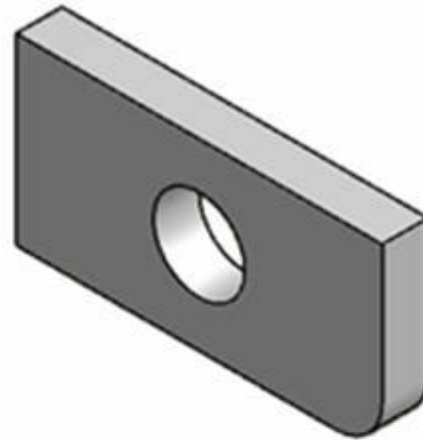

16. Holes are located by their centerlines, which may be extended and used as extension lines.

Correct

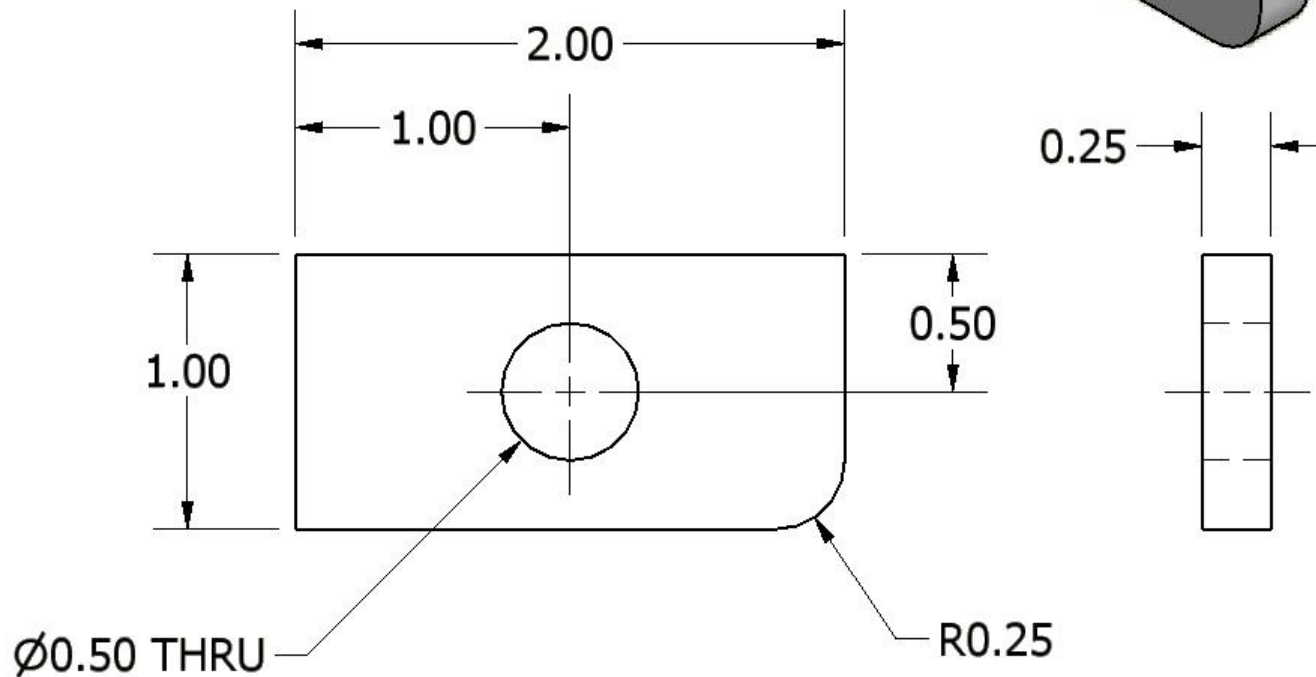
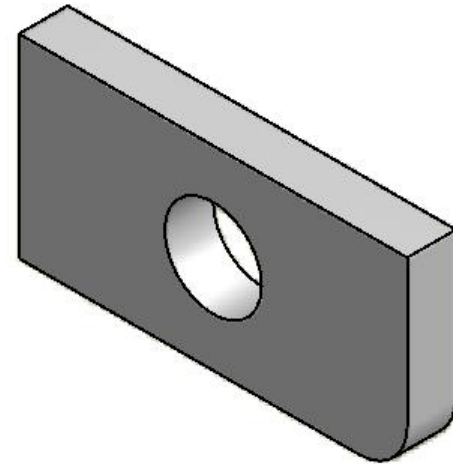

References

- Bertoline, G. (2003). *Technical graphics communication*. (3 ed.). Boston, MA: McGraw-Hill.
- Giesecke, F. [et al.] (1991). *Technical drawing*. (9 ed.). New York, NY: Macmillan Pub. Co.
- Madsen, D., Folkestad, J., Schertz, K., Shumaker, T., Stark, C., & Turpin, J. (2002). *Engineering drawing and design*. (3 ed.). Albany, NY: Delmar Thomas Learning.