



**Introduction to Engineering  
Design  
Final Examination**

**Parts A, B & C  
ANSWER KEY**

**Spring 2009  
PRACTICE EXAM**

**For Teacher Use ONLY**

## Part A – Multiple Choice Questions

Question	Answer	IED Assessment Concepts
1	B	Unit 1.1 History of Design
2	B	Unit 2.1 Design Process
3	C	Unit 2.1 Design Process
4	D	Unit 2.1 Design Process
5	B	Unit 2.2 Principles & Elements of Design
6	A	Unit 2.2 Principles & Elements of Design
7	B	Unit 3.1 Portfolio Development
8	C	Unit 3.1 Portfolio Development
9	C	Unit 4.1 Sketching & Visualization Techniques
10	C	Unit 4.2 Pictorial Sketches
11	D	Unit 4.2 Pictorial Sketches
12	A	Unit 5.2 Geometric Relationships - Constraints
13	B	Unit 5.1 Geometric Relationships - Forms and Shapes
14	D	Unit 5.1 Geometric Relationships - Forms and Shapes
15	C	Unit 6.4 Modeling - Mathematical
16	B	Unit 6.5 Modeling - Computer
17	A	Unit 6.1 Modeling - Conceptual
18	D	Unit 6.5 Modeling - Computer
19	C	Unit 6.5 Modeling - Computer
20	B	Unit 6.1 Modeling - Conceptual
21	D	Unit 6.3 Modeling - Physical
22	A	Unit 6.5 Modeling - Computer
23	B	Unit 7.4 Assembly Modeling – Sub-Assemblies
24	C	Unit 7.4 Assembly Modeling – Assembly Constraints
25	C	Unit 7.5 Assembly Modeling – Driving Constraints
26	B	Unit 8.1 Model Analysis & Verification – Mass Properties
27	A	Unit 8.1 Model Analysis & Verification – Mass Properties
28	D	Unit 8.1 Model Analysis & Verification – Mass Properties
29	A	Unit 9.1 Model Documentation – Working Drawings
30	D	Unit 9.1 Model Documentation – Working Drawings
31	A	Unit 7.1 Assembly Modeling – Adding Components
32	C	Unit 9.1 Model Documentation – Working Drawings
33	D	Unit 9.1 Model Documentation – Working Drawings
34	A	Unit 9.1 Model Documentation – Working Drawings
35	C	Unit 9.3 Model Documentation - Annotation
36	A	Unit 10.2 Presentations - Aids
37	D	Unit 10.2 Presentations - Aids
38	C	Unit 11.6 Production - Manpower and Facility Requirements
39	B	Unit 11.4 Production – Material Procurement, Handling & Cost Analysis
40	A	Unit 12.1 Marketing – Product Cost Analysis

**Answer Breakdown: A-10; B-10; C-11; D-9**

## Part A Scoring Conversion Chart

Raw Score	Conversion	Raw Score	Conversion	Raw Score	Conversion	Raw Score	Conversion
40	50	30	38	20	25	10	13
39	49	29	36	19	24	9	11
38	48	28	35	18	23	8	10
37	46	27	34	17	21	7	9
36	45	26	33	16	20	6	8
35	44	25	31	15	19	5	6
34	43	24	30	14	18	4	5
33	41	23	29	13	16	3	4
32	40	22	28	12	15	2	3
31	39	21	26	11	14	1	1

## Part B – High School Performance Exam 50 POINTS

1. Match the picture of each line type below with its corresponding name by placing the letter of the correct name in the numbered space provided.

[6 POINTS - 1 point each]      **Section 4.1: Line types**

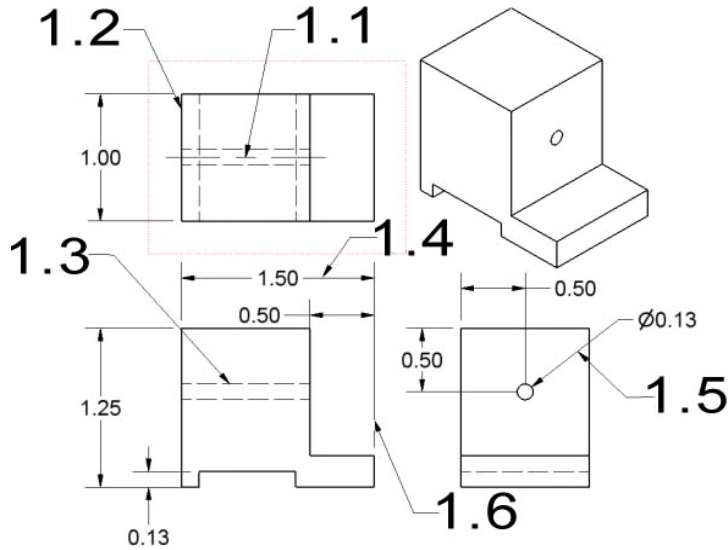

### Answer Bank

- A. Dimension Line
- B. Hidden Line
- C. Center Line
- D. Construction Line
- E. Object Line
- F. Section Line
- G. Extension Line
- H. Leader Line

1.1  C

1.4  A

1.2  E

1.5  H

1.3  B

1.6  G

2. Match the correct term from the answer bank to the definition.  
Place the letter of the mass property in the space provided.

[4 POINTS – 1 point each]

**Section 8.1: Analysis**

2.1   B   is the amount of three-dimensional space an object takes up.

2.2   E   is the extent of a 2-dimensional surface enclosed within a boundary.

2.3   A   is a 3D point defining the geometric center of a solid.

2.4   D   is the amount of matter in an object or the quantity of the inertia of the object

**Answer Bank**

- A. Centroid (Center of Gravity)
- B. Volume
- C. Principal Axes
- D. Mass
- E. Surface Area
- F. Moments of Inertia

3. Using the dimension parameters shown on the drawing below, write the equation for dimension d0 so that the thickness of the part is uniform throughout its length.

[4 POINTS]

**Parametrics**

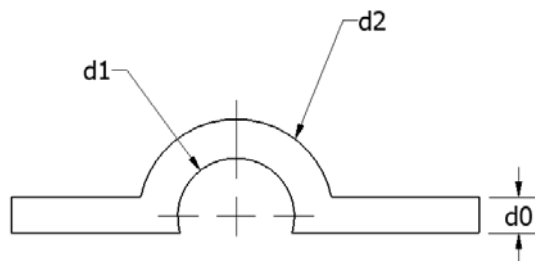
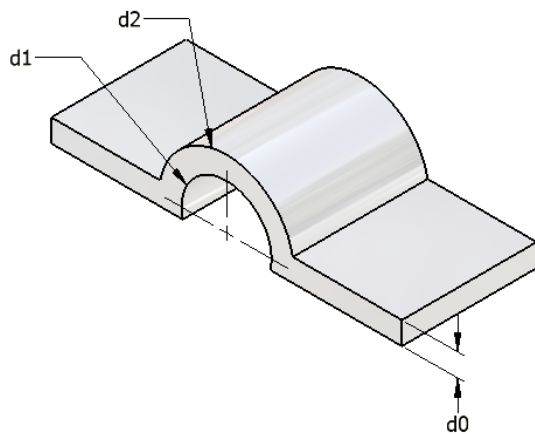

3. Ans:    $d0 = d2 - d1$

4. List the 6 Degrees of Freedom (DOF) for the coordinate axis shown below.

[6 POINTS – 1 point each]

4.1 Linear Translation along the x-axis.

4.2 Linear Translation along the y-axis.

4.3 Linear Translation along the z-axis.

4.4 Rotation about the x-axis.

4.5 Rotation about the y-axis.

4.6 Rotation about the z-axis.

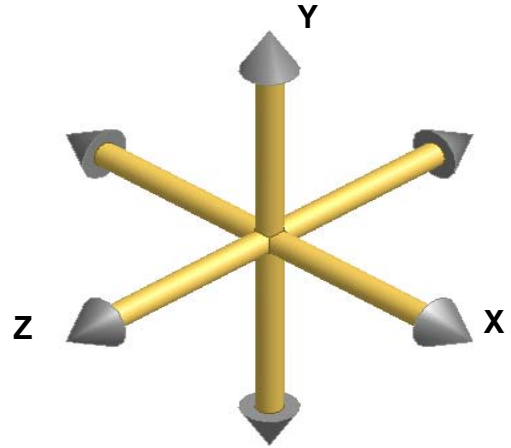

5. **Directions:** List the assembly constraints needed to properly constrain the assemblies below. Assume that Part B in each problem below is the grounded part. [6 points- 2 points each]

5.1 **A – Plate    B – Block**

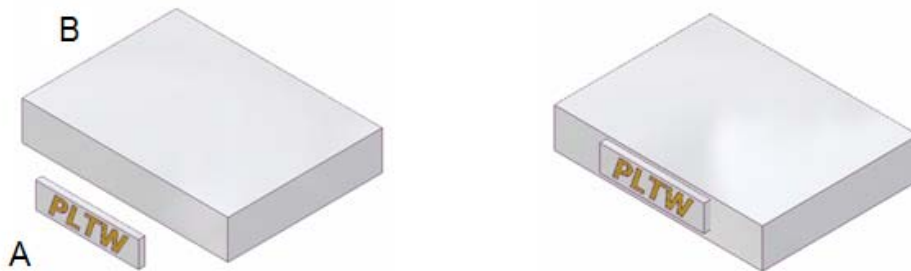

Constraint(s): Apply a **Mate** constraint between the back face of the Plate (Part A) and the corresponding front face of the Block (Part B). Apply a **Flush** constraint with an offset between the end of the Plate (Part A) and the corresponding end of the Block (Part B). Apply a **Flush** constraint with an offset between the top edge of the Plate (Part A) and the corresponding top edge of the Block (Part B).

5.2 A – Coffee Cup B – Base

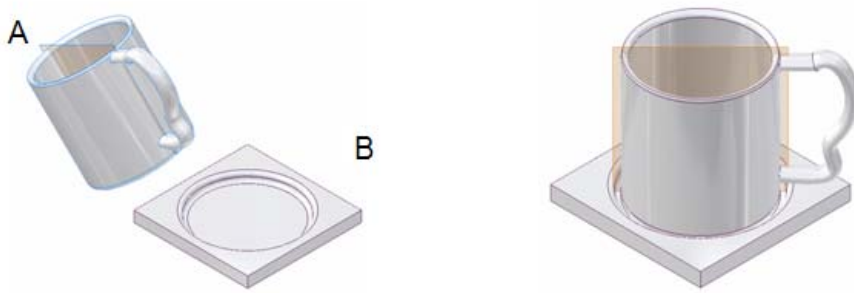

Constraint(s): Apply an **Insert** constraint between the bottom circular face of the Coffee Cup (Part A) and the corresponding circular face of the Base (Part B). Apply an **Angle** constraint with between the workplane through the Coffee Cup (Part A) and the side of the Base (Part B).

---

5.3 A – Pin B – Block

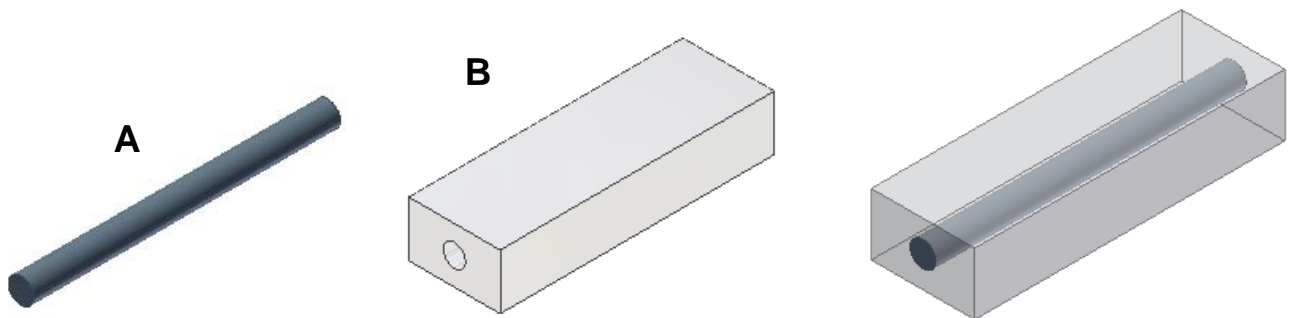

Constraint(s): Apply an **Insert** constraint between circular face of the Pin (Part A) and the corresponding hole face of the Block (Part B).

6. Many successful designs incorporate the arrangement of individual elements called Design Principles. Look at the following examples and match the graphic with the appropriate design principles from the Answer Bank. Answers may be used only once.

[4 POINTS – 1 point each]

**Answer Bank**

- Opposition
- Subordination
- Transition
- Radial Balance
- Rhythm
- Emphasis
- Proportion
- Unity

6.1 Radial Balance

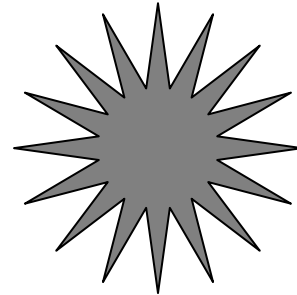

6.2 Rhythm

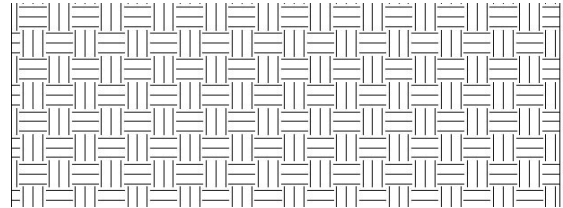

6.3 Opposition



6.4 Proportion

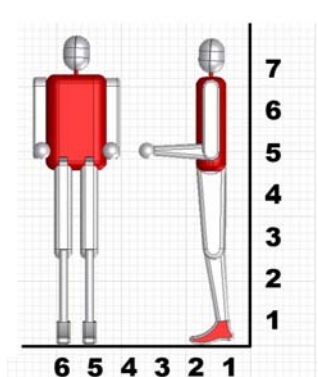

7. Whether sketching or creating mechanical parts with a 3-D solid modeling software, two common methods of creating parts are: additive (join) and/or subtractive (cut). Use the illustration of the Finished Model below to answer questions 7.1 – 7.4.

[4 POINTS]

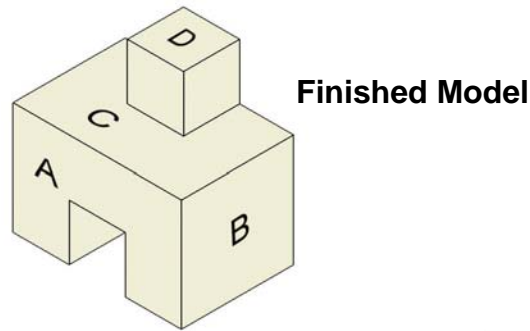

**Additive Problem:**

Describe the two steps used to create the Finished Model using an additive part creation process. Use the two sketches to the right in your description.

(2 points)

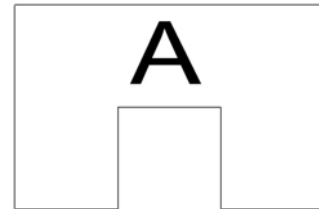

7.1 Step 1: Draw sketch A and extrude it the appropriate depth.

7.2 Step 2: Draw sketch D on top surface C and join extrude it the appropriate height.

**Subtractive Problem:**

Describe how you would use the two sketches below to transform block ABD into the Finished Model using the subtractive method. (2-points)

**Block ABD**

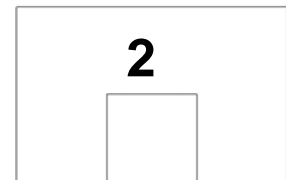
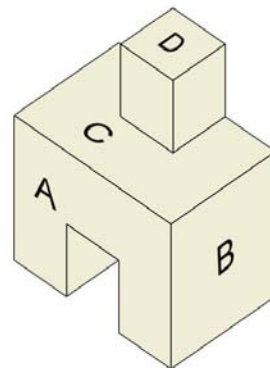
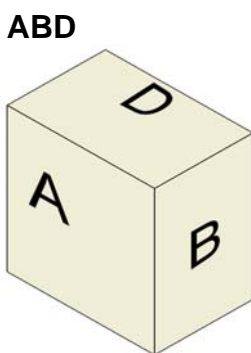

**Finished Model**

7.3 Step 3: Draw sketch 1 on surface A of Block ABD and cut extrude it through the part.

7.4 Step 4: Draw sketch 2 on top of surface D of Block ABD and cut extrude it down the appropriate distance to create cube D on the Finished Model.



8. Sketch and dimension the three orthographic projections (front, top & right-side views) of the isometric part shown at right. Grid Scale: 1 square = 1/4-inch  
 [10 POINTS] [\[Scoring Rubric is on the next page.\]](#)

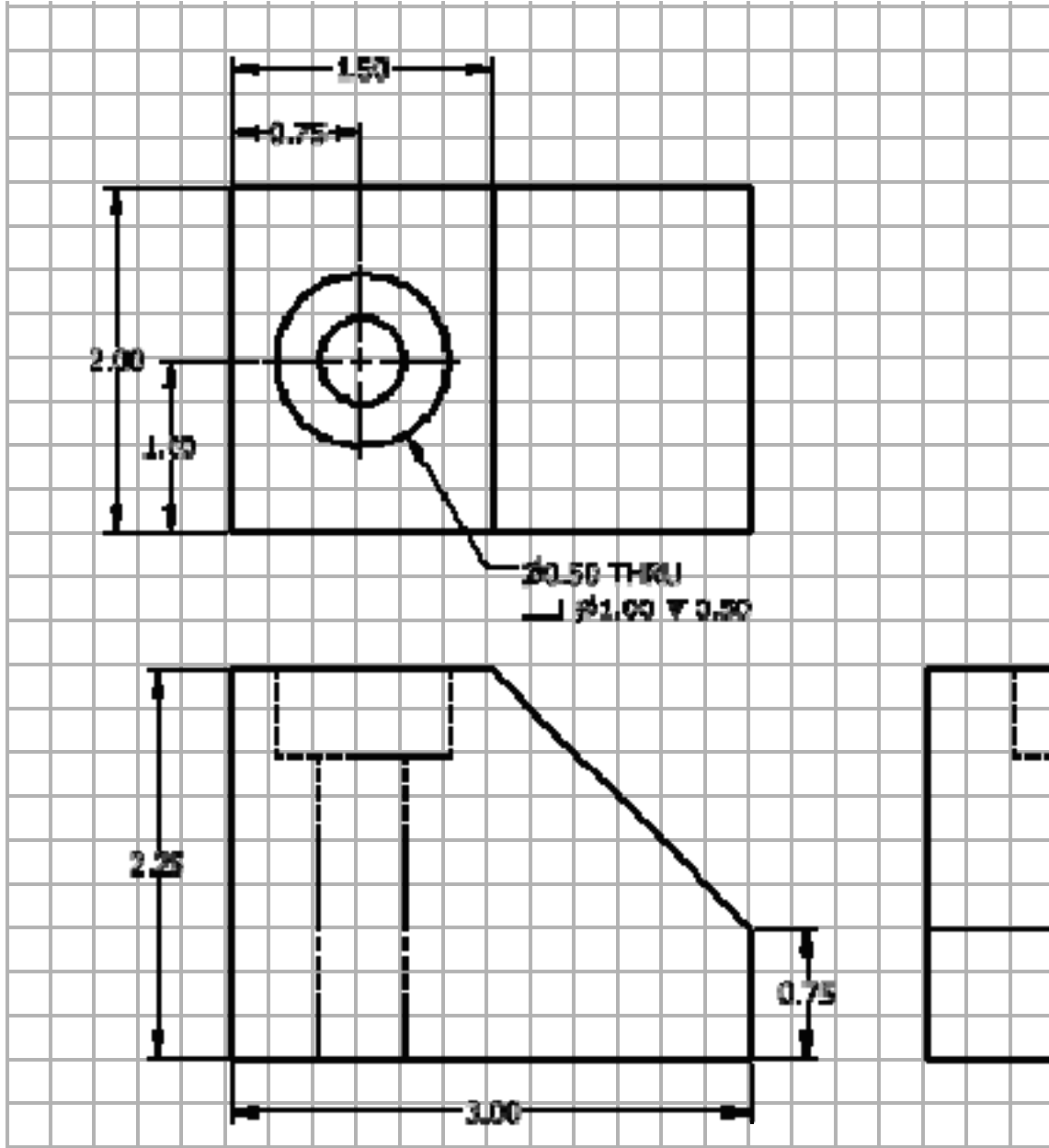
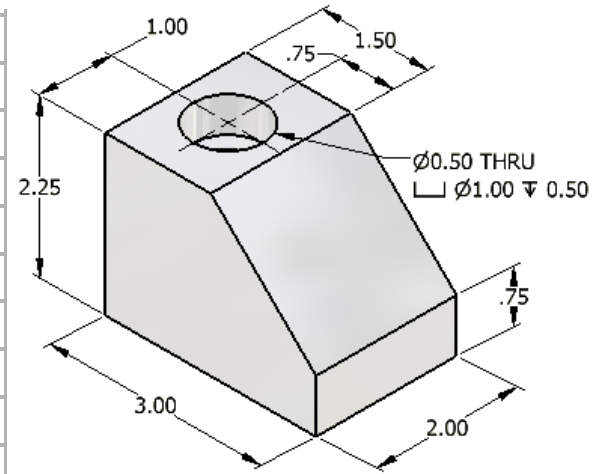

### Orthographic Drawing with Auxiliary View [7-Points]

Point Value Awarded →	3	2	1	0	
Skill or concept assessed ↓					<b>Total Orthographic Alignment (3)</b>
<b>Orthographic Alignment</b>	All features of the front, top and right-side views are aligned orthographically.	Most features of the front, top and right-side views are aligned orthographically – some minor misalignment of features between views.	Significant misalignment between 2 or more views.	Drawing views are not orthographically aligned.	_____
Point Value Awarded →	4	3	2	1	
<b>Drawing Features</b>	Front, top and right-side views are complete and are the correct shape and size.	Two views are complete and correct - One view has a small amount of missing or incorrectly sized features.	Two or more views have missing or incorrectly sized features (OR) two views are complete and correct but the third view is missing.	Significant errors or missing features in all drawing views.	<b>Total Drawing Features (4)</b>
					_____

### Dimensions [3-Points]

Point Value Awarded →	3	2	1	0	
Skill or concept to be assessed ↓					<b>Total Dimensioning (3)</b>
<b>Dimensioning</b>	All dimensions and annotations are present and have correct placement.	More than half of the dimensions and annotations are present and have correct placement.	Fewer than half of the dimensions and annotations are present and have correct placement.	Not dimensioned	_____

**Total Score for Orthographic Drawing with Auxiliary (out of 10 points):** \_\_\_\_\_

9. Use the drawing below to answer the following questions.

**Print Reading**

[6 POINTS – 1 point each]

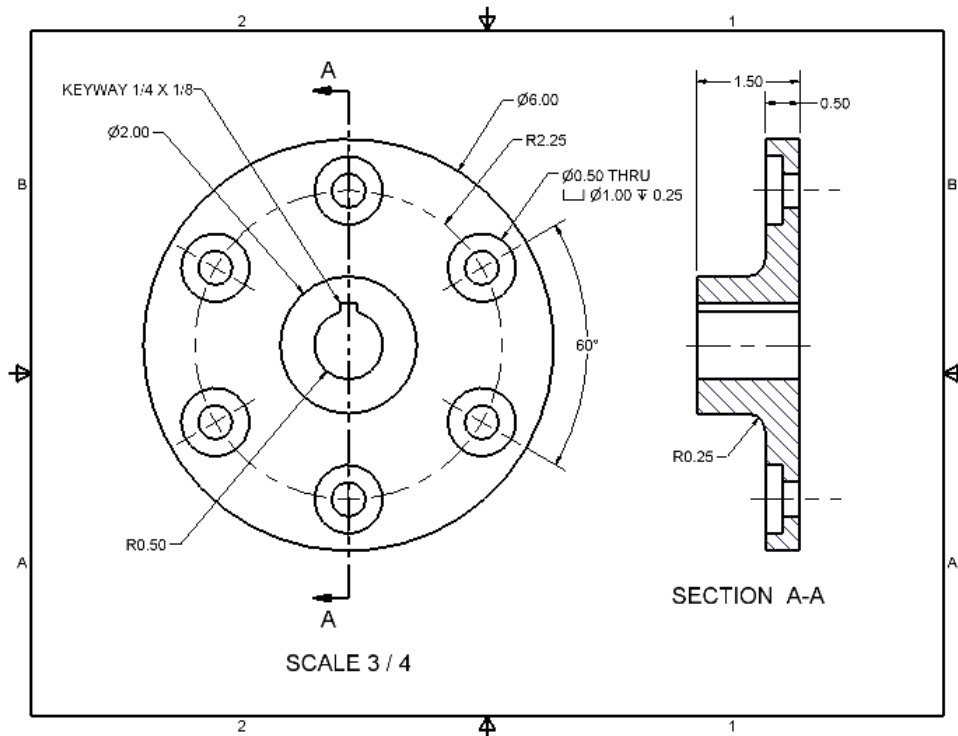

- 9.1 What is the fillet radius? R.25
- 9.2 What is the depth of the counter bore? .25
- 9.3 What is the angular measurement between the counter bored holes? 60 degrees
- 9.4 What is the overall size of the keyway? 1/4 x 1/8
- 9.5 What is the distance from the center of the part to the center of the counter bored holes? 2.25
- 9.6 What is the overall thickness of the part? 1.50

## Part C – College Credit Performance Exam

1. Identify the three line types indicated on the orthographic drawing below and explain why each is used?

[6-POINTS: 1 point for each line type, 1 point for each explanation of use]

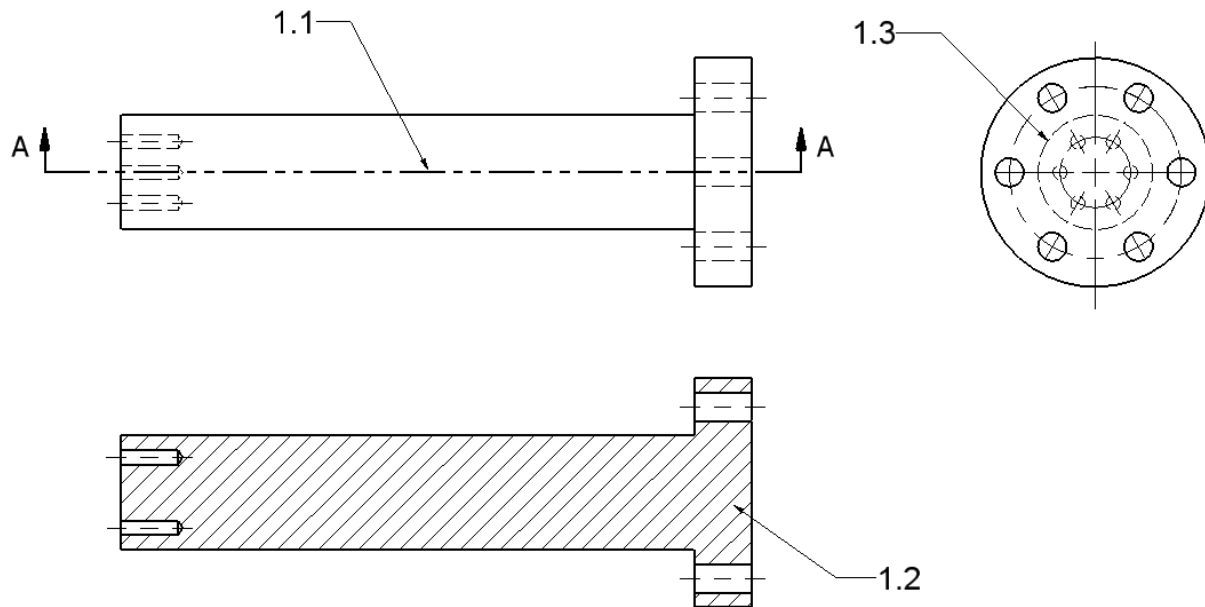

SECTION A-A  
SCALE 1 : 1

1.1

Line type: Cutting Plane Line

Purpose: A cutting plane line is used to show where a part has been cut in the adjacent section view and in which direction the section should be viewed.

1.2

Line type: Hatch Marks or Section Lines

Purpose: Hatch Marks or Section Lines are used to show where material has been sliced by the cutting plane in a section view.

1.3

Line type: Hidden Lines

Purpose: Hidden Lines are used to show edges that are not visible as object lines in an orthographic view.

2. Calculate the surface area for the part below and determine the amount of stain the manufacturer would have to buy in order to cover 80 wood blocks; assuming each quart would cover 160 square inches. Show your work below.

What is the surface area of the part? 9.5 in<sup>2</sup>

How many quarts of stain should be ordered for 80 blocks? 5 quarts

[4-POINTS: 2 points for surface area, 2 points for amount of stain]

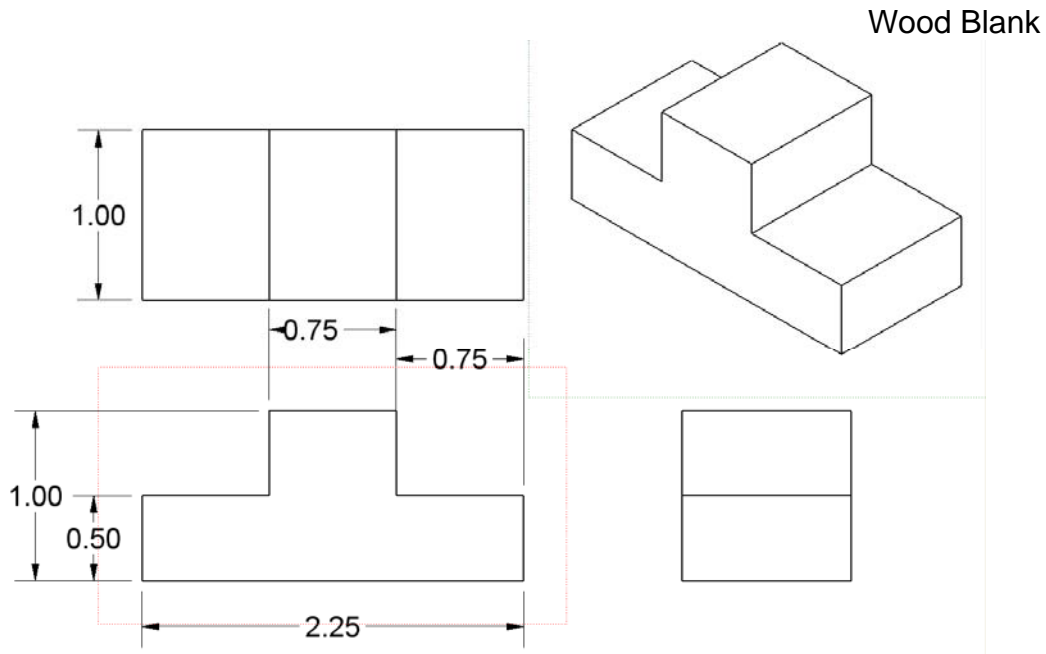

**Surface Area Calculations:**

Surface area of front and back:  $[2.25(.5) + .75(.5)] * 2 = 3 \text{ in}^2$

Surface area of top and bottom:  $(2.25 \times 1) * 2 = 4.5 \text{ in}^2$

Surface area of left and right sides:  $(1 \times .5) * 4 = 2 \text{ in}^2$

**Surface Area of Block:**  $3 + 4.5 + 2 = \underline{9.5 \text{ in}^2}$

**Quantity of Stain Calculations:**

Total Surface Area = Surface Area of Block x Number of Blocks

Total Surface Area =  $9.5 \text{ in}^2 \times 80$

Total Surface Area =  $760 \text{ in}^2$

Quarts of Stain = Total Surface Area ÷ Area Covered in 1 Quart

Quarts of Stain =  $760 \text{ in}^2 \div 160 \text{ in}^2 = 4.75$

**Quarts of Stain** = rounded to the nearest quart = 5 quarts

3. Using the dimension parameters shown on the drawing below, write the equation for d2 so that Hole B is always centered between the left edge of the block and the left edge of Hole A.

[5-POINTS]

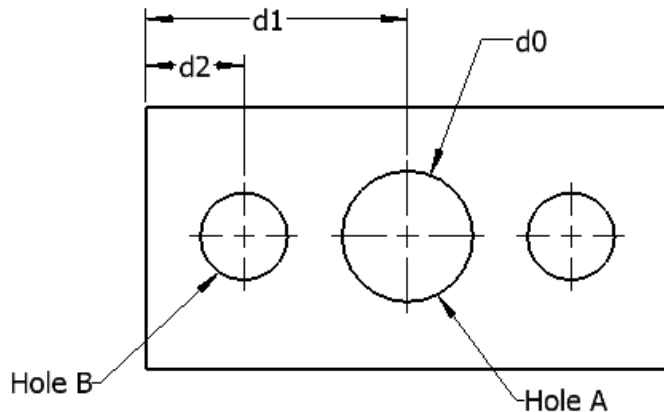

Equation:  $d2 = (d1 - d0/2)/2$

4. List the assembly constraints needed to properly constrain the parts in the three assemblies shown below. List the Degrees of Freedom (DOF), if any, that remain on Part A based on the constraints applied. Assume that Part B in each problem below is the grounded part.

[9-POINTS – 2 points for listing constraints, 1 point for identifying degrees of freedom]

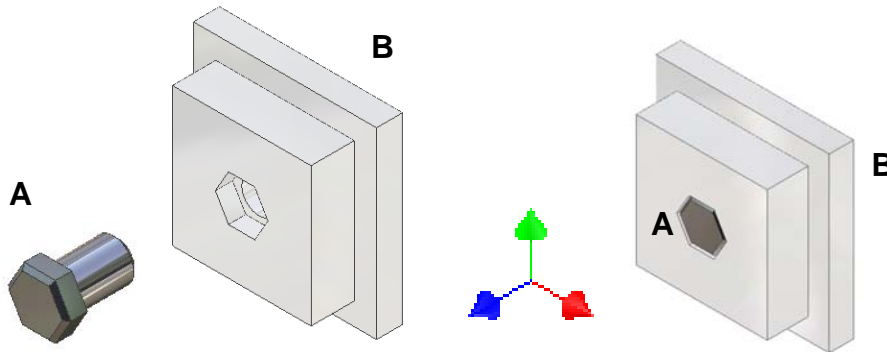

4.1

Assembly Constraints: Apply an **Insert** constraint between the underside of the hex head of the pin (Part A) and bottom of the hex hole in the block (Part B). Apply a **Face Mate** between one side of the hex head (Part A) and a corresponding side of the hex hole (Part B).

List the Degrees of Freedom that remain on Part A (be specific).

There are no degrees of freedom. The parts are fully constrained.

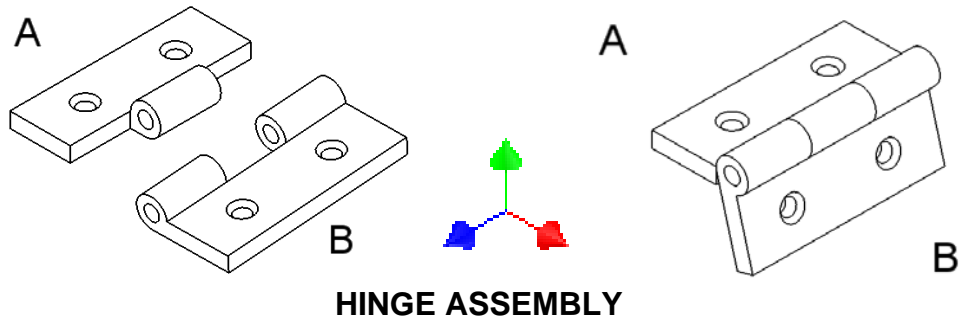

### HINGE ASSEMBLY

Note: The user wants to drive one of the constraints to show the articulation of the hinge.

4.2

Assembly Constraints: Apply an **Insert** constraint between the face and center axis of the cylindrical barrel on hinge A with the face and center axis of the cylindrical barrel on hinge B. Apply an **Angle Constraint** between the flat face or edge of hinge A with the opposing flat face or edge of hinge B. (for creating the drive constraint)

List the Degrees of Freedom that remain on Part A (be specific).

There are no degrees of freedom. The parts are fully constrained.

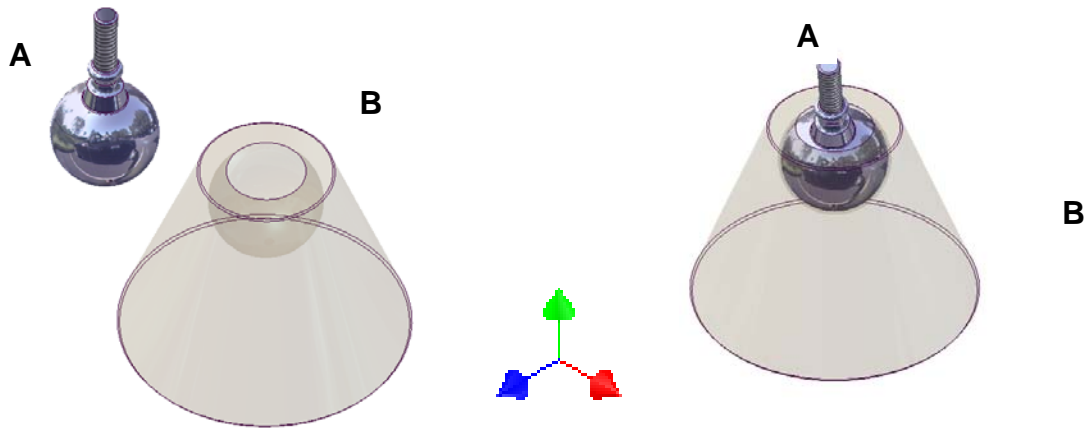

### Ball Joint and Socket

4.3

Assembly Constraints: Apply a **Tangent** constraint between the spherical ball of the ball joint and the spherical cavity of the socket. Apply an **Angle** constraint between the center axis of the ball joint stem (Part A) and the top flat surface of the socket (Part B).

List the Degrees of Freedom that remain on Part A (be specific):

Rotation about the vertical (Y) axis.

## 5. Part Model Creation

[5-POINTS – 1 point each]

The process of developing a 3D CAD solid model of a hammer head has been divided into four phases. Each phase lists specific steps in the model's creation. Study the graphics below and the steps that are given for each phase. Then complete the process by writing the missing steps on the lines provided. In each case, you must identify the specific CAD function(s) being used, along with the name of the model feature (as labeled below) that you are referencing.

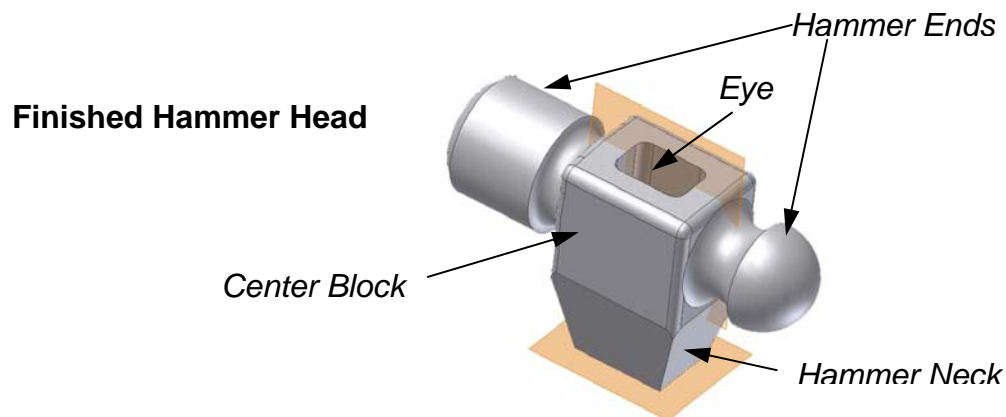

### Phase 1: Creating the Center Block

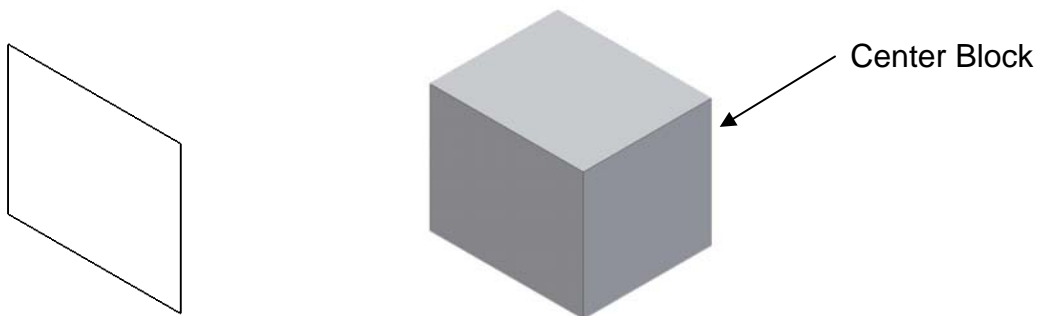

Step 5.1: **Draw** and **dimension** a sketch of the **Center Block** feature.

Step 5.2: **Extrude** the sketch of the **Center Block** to the appropriate dimension.



## Phase 2: Creating two Hammer Ends

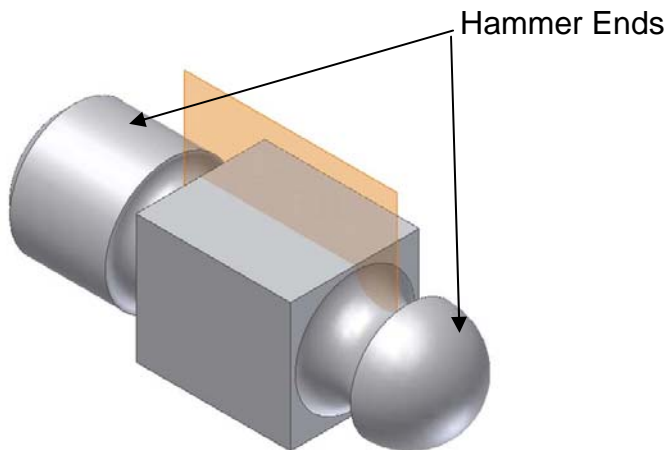

Step 5.3: **Offset** a vertical **work plane** halfway through the width of the **Center Block**.

Step 5.4: Create a **sketch plane** on the **work plane**.

Step 5.5: Draw and dimension half of the profile of the two **Hammer Ends** and constrain them to the geometry of the **Center Block**.

Step 5.6: [Use the Revolve tool and perform a Full Revolve on the sketches of the Hammer Ends.](#)

## Phase 3: Creating the Hammer Neck

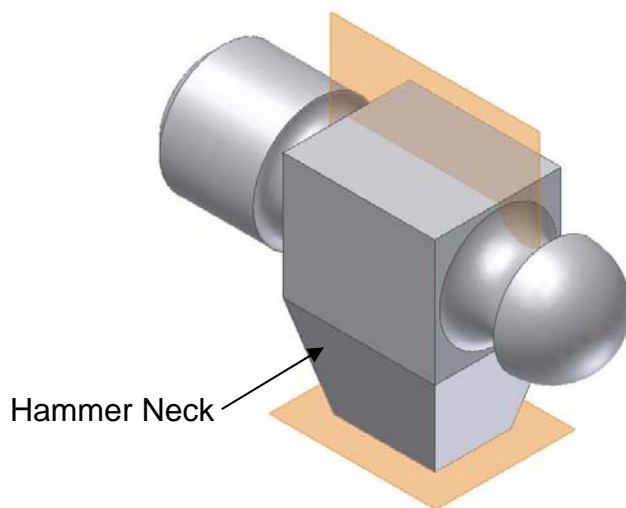

Step 5.7: **Offset** a horizontal **work plane** from the bottom of the **Center Block** to a distance that is equal to the height of the hammer neck.

Step 5.8: Create a new **sketch plane** on the horizontal **work plane**.

Step 5.9: [Draw and dimension a rectangle on the sketch plane and constrain it to the bottom of the Center Block.](#)

Step 5.10: Loft the bottom of the **Center Block** to the Sketch of a rectangle.

#### Phase 4: Creating the Eye and Rounded Edges on the Hammer Head

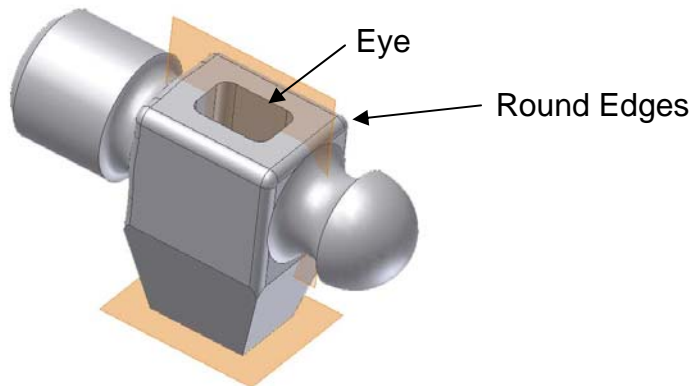

Step 5.11: Create a new **sketch plane** on the top of the **Center Block**.

Step 5.12: Draw a sketch of a rectangle with corner fillets and constrain it to the Hammer Head.

Step 5.13: [Use the cut feature of the extrude command to remove the hammer eye through all of the part.](#)

Step 5.14: Use the [Fillet](#) tool to create the r rounded edges on the **Center Block**.

**6. Use the Answer Bank to fill in the missing steps of the design process by placing the letter that corresponds to the missing step in the blank space provided. [6 Points – 1 point each]**

**Phase 1: Problem Identification**

Description: Identify areas of need or want through market research. Compose a formalized design brief stating the problem that needs to be solved. Identify all constraints that affect the design and classify the constraints within the various resources available.

Phase 2:           **C**          

Description: Brainstorming occurs and ideas are collected and/or recorded, often in graph form. Research is completed. Thumbnail sketches of ideas are drawn.

**Phase 3: Refinement of Preliminary Ideas**

Description:           **F**          

**Phase 4: Design Analysis**

Description:           **D**          

Phase 5:           **A**          

Description: Detailed documentation of final design is created. Prototyping is done. Testing and analysis completed.

Phase 6:           **E**          

Description:           **B**          

**Phase 7: Presentation**

Description: Several forms of reporting may be used to adequately express the design solution to any and all parties involved.

**ANSWER BANK:**

- A. Development and Implementation
- B. Reassess the design specifications. Implement any modifications that might be necessary. Update drawings.
- C. Conceptualization
- D. Compare alternatives and specifications. Create a decision-making matrix to compare the attributes of the various design solutions and analyze trade-offs. Generate alternative solutions that better satisfy the design criteria. Narrow the available solutions and select a final design.
- E. Optimization
- F. Workable solutions are identified. Detailed/annotated sketches are developed. Analysis of possible solutions assembled.

**7. ORTHOGRAPHIC DRAWING: [10 points]**

Sketch a front view, full section of the mounting bracket and dimension the part.

**Drawing: 7 Points**

**Dimensions: 3 Points**

*See scoring rubric on next page*

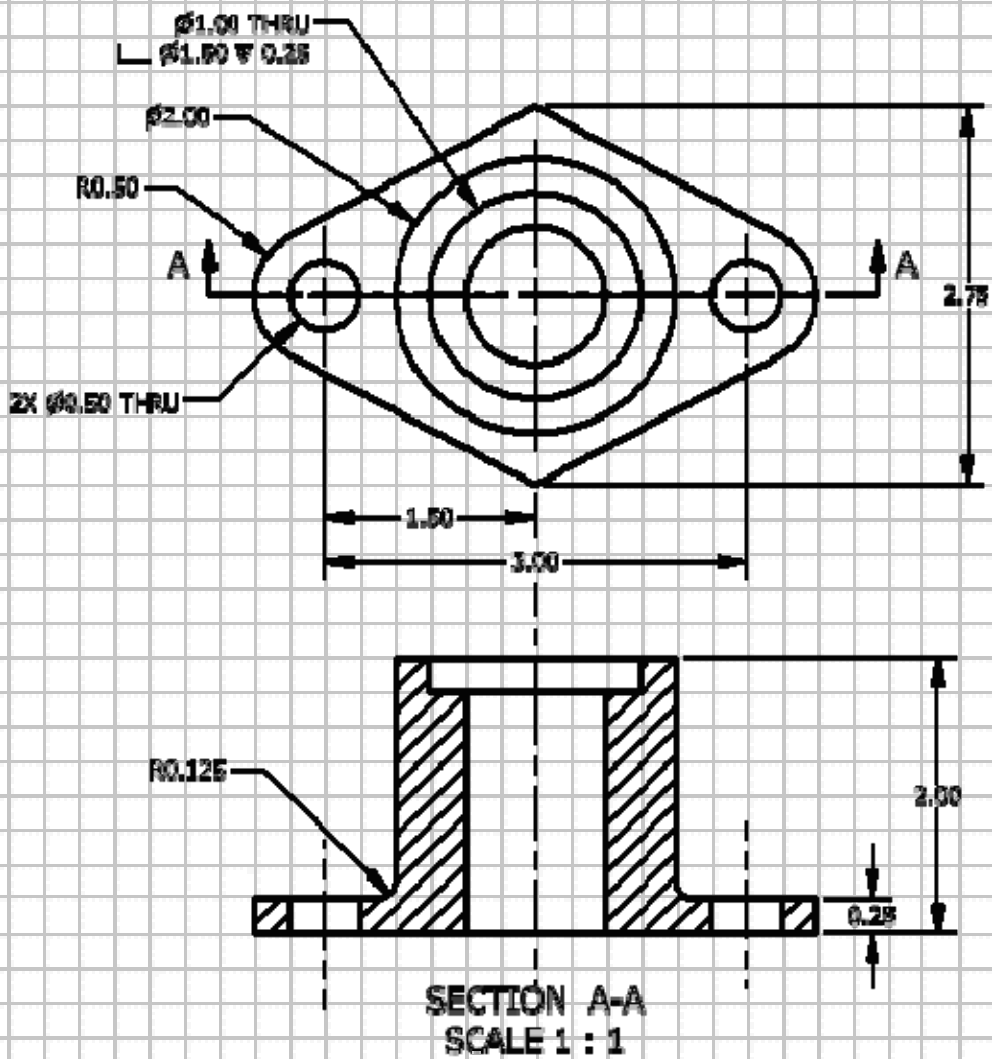

### Section Drawing [7-Points]

Point Value Awarded →	3	2	1	0	
Skill or concept assessed ↓					<b>Total Orthographic Alignment (3)</b> _____
<b>Section Alignment</b>	All features of the front section view are aligned correctly.	Most features of the section view are aligned correctly, some minor misalignment of features between views.	Significant misalignment between the top view and the section view.	Views are not aligned.	
Point Value Awarded →	4	3	2	1	
					<b>Total Drawing Features (4)</b> _____
<b>Drawing Features</b>	The full section front view is complete and is the correct shape and size. Hatch is correctly sized and placed.	The full section front view is mostly complete – some minor features are missing – Hatch is correctly placed. Incorrect hatch scale or pattern.	Front section view is incorrectly sized and has incorrect or missing hatch pattern and placement.	Significant errors or missing features in the front section view. Hatch pattern and placement is incorrect or missing.	

### Dimensions [3-Points]

Point Value Awarded →	3	2	1	0	
Skill or concept to be assessed ↓					<b>Total Dimensioning (3)</b> _____
<b>Dimensioning</b>	All dimensions and annotations are present and have correct placement.	More than half of the dimensions and annotations are present and have correct placement.	Fewer than half of the dimensions and annotations are present and have correct placement.	Not dimensioned	

**Total Score for Section Drawing (out of 10 points):** \_\_\_\_\_

### 8. Print Reading

[5 POINTS - 1 point each]

Use the drawing of the pivot arm to answer the following questions.

- 8.1 What is size of dimension **A**? 1
- 8.2 What is the thickness of the part at **B**? .50
- 8.3 What is the overall length of the part?  $6.13+.50+.62$  **ANS = 7.25**
- 8.4 What is the width of the keyway? .13
- 8.5 From what material is the part made? Aluminum 6061